

HS

KELAJAK TEKNOLOGIYALARI VA SUN'IIY INTELLEKT

RESPUBLIKA ILMIIY-AMALIIY
MASOFAVIY KONFERENSIYASI



zenodo



innopublication.com



“KELAJAK TEXNOLOGIYALARI VA SUN’IY INTELLEKT”
nomli respublika ilmiy-amaliy masofaviy konferensiyasi
VOLUME-1, ISSUE-2, 2026

Ushbu to’plamda **“KELAJAK TEXNOLOGIYALARI VA SUN’IY INTELLEKT”** nomli respublika ilmiy-amaliy masofaviy konferensiyasining 2026-yil 2-soniga qabul qilingan maqolalar nashr etilgan.

“Kelajak texnologiyalari va sun’iy intellekt” nomli respublika ilmiy-amaliy masofaviy konferensiyasi zamonaviy axborot texnologiyalari, sun’iy intellekt, raqamli transformatsiya va innovatsion yechimlar sohasidagi ilmiy tadqiqotlarni qo’llab-quvvatlashga qaratilgan. Konferensiya materiallari tegishli soha mutaxassislari tomonidan ko’rib chiqilgan original ilmiy maqolalar va tezislardan iborat bo’lib, unda professor-o’qituvchilar, doktorantlar, magistrantlar, iqtidorli talabalar, IT sohasi vakillari hamda mustaqil tadqiqotchilar ishtirok etishlari mumkin.

Konferensiya har oyda bir marotaba tashkil etilib, barcha ishtirokchilarga **sertifikat, maqola pdfi, DOI raqami** hamda **konferensiya to’plami** taqdim etiladi.

“INNOVATIVE PUBLICATION”- ILMIY TADQIQOTLARNI
QO’LLAB-QUVVATLASH MARKAZI

ILMIY-ONLAYN KONFERENSIYA TO’PLAMI
СБОРНИК НАУЧНЫХ-ОНЛАЙН КОНФЕРЕНЦИЙ
SCIENTIFIC-ONLINE CONFERENCE COLLECTION

<http://innopublication.com>





"KELAJAK TEKNOLOGIYALARI VA SUN'IY INTELLEKT"
nomli respublika ilmiy-amaliy masofaviy konferensiyasi
VOLUME-1, ISSUE-2, 2026

**ROLE OF CONTINUOUS PHYSICAL ACTIVITY MONITORING IN THE
PREDICTION OF GESTATIONAL DIABETES: OPPORTUNITIES OF
WEARABLE DEVICES**

Nuratdinova Kumar Nurazizovna

*Tashkent University of Information Technologies named after Muhammad al-
Khwarizmi*

E-mail: nuratdinovakumar28@gmail.com

Abstract. Gestational diabetes mellitus (GDM) remains one of the most pressing issues in modern obstetrics, affecting up to 15-20% of pregnancies worldwide. One of the key modifiable causes of GDM development is hypothermia. Traditional methods for assessing physical activity based on patient self-reports often suffer from subjectivity and low accuracy. This article examines the potential for using wearable devices (accelerometers and smartwatches) to objectively and continuously collect data on the motor activity of pregnant women. Special attention is paid to integrating this data into predictive models based on machine learning. The analysis of "digital biomarkers" allows for the early detection of carbohydrate metabolism disorders, opening up new opportunities for personalized prevention and timely lifestyle adjustment.

Keywords: gestational diabetes, wearable devices, physical activity, monitoring, digital healthcare, machine learning.

**РОЛЬ НЕПРЕРЫВНОГО МОНИТОРИНГА ФИЗИЧЕСКОЙ
АКТИВНОСТИ В ПРЕДИКЦИИ ГЕСТАЦИОННОГО САХАРНОГО
ДИАБЕТА: ВОЗМОЖНОСТИ НОСИМЫХ УСТРОЙСТВ**

Нуратдинова Кумар Нуразизовна

*Ташкентский университет информационных технологий имени Мухаммеда
аль-Хорезми*

E-mail: nuratdinovakumar28@gmail.com



“KELAJAK TEKNOLOGIYALARI VA SUN’IY INTELLEKT”
nomli respublika ilmiy-amaliy masofaviy konferensiyasi
VOLUME-1, ISSUE-2, 2026

Аннотация . Гестационный сахарный диабет (ГСД) остается одной из наиболее актуальных проблем современного акушерства, затрагивая до 15–20% беременностей во всем мире. Одной из ключевых модифицируемых причин развития ГСД является гиподинамия. Традиционные методы оценки физической активности, основанные на самоотчетах пациентов, часто страдают от субъективности и низкой точности. В данной статье рассматривается потенциал использования носимых устройств (акселерометров и смарт-часов) для объективного и непрерывного сбора данных о двигательной активности беременных. Особое внимание уделяется интеграции этих данных в прогностические модели на базе машинного обучения. Анализ «цифровых биомаркеров» позволяет выявлять риски нарушения углеводного обмена на ранних этапах, что открывает новые возможности для персонализированной профилактики и своевременной коррекции образа жизни.

Ключевые слова: *гестационный сахарный диабет , носимые устройства , физическая активность, мониторинг, цифровое здравоохранение, машинное обучение.*

Введение

В последние десятилетия наблюдается глобальный рост заболеваемости гестационным сахарным диабетом, что обусловлено как изменением диагностических критериев, так и увеличением числа женщин с избыточной массой тела. ГСД сопряжен с серьезными рисками: макросомией плода, преэклампсией и повышенной вероятностью развития диабета 2-го типа у матери в будущем. Ключевым инструментом профилактики признана физическая активность. Однако врачи в клинической практике по-прежнему опираются на анкеты и опросы, которые не дают объективной картины. Пациентки склонны



“KELAJAK TEKNOLOGIYALARI VA SUN’IY INTELLEKT”
nomli respublika ilmiy-amaliy masofaviy konferensiyasi
VOLUME-1, ISSUE-2, 2026

завышать интенсивность своих тренировок или ошибочно оценивать повседневную активность. Целью данной статьи является анализ того, как переход от субъективных опросов к объективному мониторингу с помощью трекеров может качественно изменить подход к раннему выявлению рисков ГСД. Современные трекеры (например, Apple Watch, Garmin, Fitbit) позволяют фиксировать широкий спектр данных, выходящих за рамки простого подсчета шагов:

- **Интенсивность нагрузки** : оценка энергозатрат в метаболических эквивалентах.

- **Вариабельность сердечного ритма** : индикатор состояния вегетативной нервной системы и уровня общего стресса организма.

- **Качество и продолжительность сна**: дефицит сна напрямую коррелирует с нарушением толерантности к глюкозе.

- **Сидячее поведение** : фиксация длительных периодов неподвижности, что является независимым фактором риска ГСД.

Связь паттернов движения и гликемического профиля. Биохимический аспект физической нагрузки при беременности заключается в активации белков-переносчиков глюкозы в мышечной ткани. Регулярная активность умеренной интенсивности повышает чувствительность рецепторов к инсулину, снижая физиологическую инсулинорезистентность, характерную для второго и третьего триместров. Трекеры позволяют точно зафиксировать «окна активности», наиболее благоприятно влияющие на постпрандиальный (после еды) уровень сахара.[1]

Интеграция данных с носимых устройств в алгоритмы машинного обучения позволяет создавать прогностические модели с высокой специфичностью. Анализируя комбинацию клинических данных (возраст, ИМТ) и динамических



“KELAJAK TEKNOLOGIYALARI VA SUN’IY INTELLEKT”
nomli respublika ilmiy-amaliy masofaviy konferensiyasi
VOLUME-1, ISSUE-2, 2026

параметров (среднедневное количество шагов, частота пульса в покое), ИИ может формировать *цифровой биомаркер риска ГСД*. Такие модели способны предсказать развитие заболевания еще до проведения стандартного перорального глюкозотолерантного теста (ПГТТ) на 24–28 неделе. Главным достоинством использования трекеров является *объективность данных*. В отличие от дневников самоконтроля, где пациентки могут непроизвольно исказить информацию, акселерометры фиксируют реальную физическую нагрузку, включая «невидимую» активность (бытовую ходьбу, домашние дела).[2]

Непрерывность мониторинга позволяет врачу видеть динамику состояния в течение всей недели, а не только в моменты визитов в клинику. Это создает фундамент для развития *дистанционного контроля (телемедицины)*: врач может получать автоматические уведомления, если уровень активности пациентки из группы риска падает ниже критической отметки, и своевременно корректировать рекомендации. Несмотря на прогресс, сохраняется проблема вариативности точности. Датчики разных производителей используют различные алгоритмы обработки сигналов, что может приводить к расхождениям в подсчете энергозатрат. Другим важным фактором является *комплаенс (приверженность лечению)*. Для построения точного прогноза ГСД требуется, чтобы женщина носила устройство практически круглосуточно (24/7). На практике это может вызывать дискомфорт, раздражение кожи или простую забывчивость, что ведет к «дырам» в данных и снижает точность прогностических моделей.[3]

Заключение

Интеграция носимых устройств в систему антенатального наблюдения представляет собой качественный переход от традиционной описательной медицины к предиктивной и персонализированной модели. Проведенный анализ показывает, что непрерывный мониторинг физической активности позволяет не



“KELAJAK TEXNOLOGIYALARI VA SUN’IY INTELLEKT”
nomli respublika ilmiy-amaliy masofaviy konferensiyasi
VOLUME-1, ISSUE-2, 2026

только объективизировать данные о стиле жизни беременной, но и выявлять скрытые паттерны поведения, коррелирующие с риском развития гестационного сахарного диабета задолго до появления клинических симптомов. Несмотря на существующие технологические вызовы и вопросы конфиденциальности данных, потенциал использования «цифровых биомаркеров» в сочетании с алгоритмами машинного обучения огромен. Это открывает путь к созданию интеллектуальных систем поддержки принятия врачебных решений, которые могут значительно снизить частоту осложнений, связанных с ГСД.

Список литературы

1. Абдуллаева Г. А. Частота встречаемости гестационного сахарного диабета в различных регионах республики / Г. А. Абдуллаева // Yangi O‘zbekiston Talabalari Axborotnomasi. — 2024. — № 5. — С. 12-15.
2. Analysis of mobile applications created to assess the risk of developing gestational diabetes mellitus / Uzbekistan Healthcare Tech Review // ResearchGate. — 2023. — URL: [ссылка] (дата обращения: 04.05.2026).
3. Gunderson E. P. Wearable Device Patterns and Gestational Diabetes Risk: A Prospective Cohort Study / E. P. Gunderson // Diabetes Care. — 2023. — № 46. — P. 340-348.



Improvement of Technological Process Efficiency in Rolling Mills

*Tashkent State Technical University named after Islam Karimov , Department of
Metal Technology master's student*

Normengliyev Umidjon Abdixoliq ugli

Annotation. Increasing requirements for the quality of sheet metal products, especially their dimensional precision, make it necessary to enhance rolling technologies, develop computer-aided systems for process parameters, and introduce improved designs of deformation equipment. Reduced accuracy in many rolled products negatively impacts not only metallurgical processing operations but also leads to poorer technical and economic performance of the final products.

Key words: Technical progress, technical and economic indicators of rolled products, Mathematical modeling, Calculation algorithm, Mathematical models of the rolling process have been solved.

In this context, it became necessary to develop algorithms for determining optimal rolling regimes that ensure the production of strips with the required quality while maintaining equipment productivity. A key feature of the proposed approach is the application of the stochastic automata method as a tool for identifying the extremum of the objective function. Enhancing metal forming processes, particularly rolling, relies on both theoretical analysis and experimental investigation of plastic deformation behavior.

Accordingly, the creation of rolling regimes that improve sheet accuracy—based on mathematical models incorporating real values of metal deformation resistance and actual deformation conditions—as well as the design of new devices for additional strip calibration, is of significant importance.

The increasing demands placed on the quality of sheet metal products, especially regarding dimensional precision, call for advancements in rolling technologies, the development of computer-aided systems for process parameter design, and the



“KELAJAK TEKNOLOGIYALARI VA SUN’IY INTELLEKT”
nomli respublika ilmiy-amaliy masofaviy konferensiyasi
VOLUME-1, ISSUE-2, 2026

introduction of improved deformation unit designs.

The method differs from those currently used in calculating optimal rolling conditions in that it does not require simplification of mathematical models, additivity of the objective function, and linearity of constraints.

To achieve the set goal, the following tasks were solved during the work:

- * creation of a laboratory software and hardware complex for studying the process of rolling copper and brass;
- * study of force parameters on an operating rolling mill and determination of possible fluctuations in rolling forces;
- * study of the influence of contact friction on the rolling forces of metals and alloys of a specific chemical composition;

Mathematical models of the rolling process used in algorithms for calculating optimal modes must satisfy the conflicting requirements of simplicity and high accuracy of calculations. Such accuracy can be ensured only if the influence of the design parameters of the mill, the features of the distribution of elastic deformations of the working rolls along their length at the point of contact with the rolled strip and the influence of the random nature of the change in the parameters of the rolled product are taken into account.

The developed models for calculating the thickness variation of the rolling strip satisfy the specified requirements. Thus, in the model for calculating the longitudinal thickness variation, in addition to the main factors, the combined effect of the roll and winder beating in the thickness variation, the model for calculating the transverse thickness variation, in contrast to the existing ones, takes into account the nature of the distribution of radial flattening along the length of the bridge of their contact with the rolled strip and the effect of random changes in the transverse thickness variation of the rolled blank. The assessment of product quality and the change in parameters

“KELAJAK TEKNOLOGIYALARI VA SUN’IY INTELLEKT”
nomli respublika ilmiy-amaliy masofaviy konferensiyasi
VOLUME-1, ISSUE-2, 2026

characterizing quality must be expressed through clear statistical criteria. This can be achieved most fully using methods of correlation-spectral analysis.

Regression equations have been obtained that relate the values of resistance to deformation of copper and brass with hardness indices, making it possible to expand the areas of application of non-destructive testing methods for mechanical properties of rolled products. One of the most universal methods of search optimization is the method of automata optimization. The emergence of ideas of automata optimization is associated with the creation of automatic control systems (robots) capable of replacing humans, so the first works on the theory of automata were devoted to modeling biological systems. The goal of the research is to build not only automata optimization systems, but also control systems composed of groups of automata.

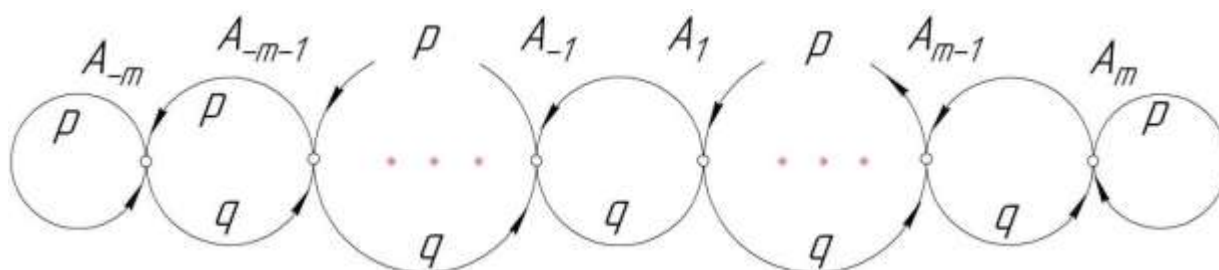

Fig.1.1. Graph of the Tsetlin machine

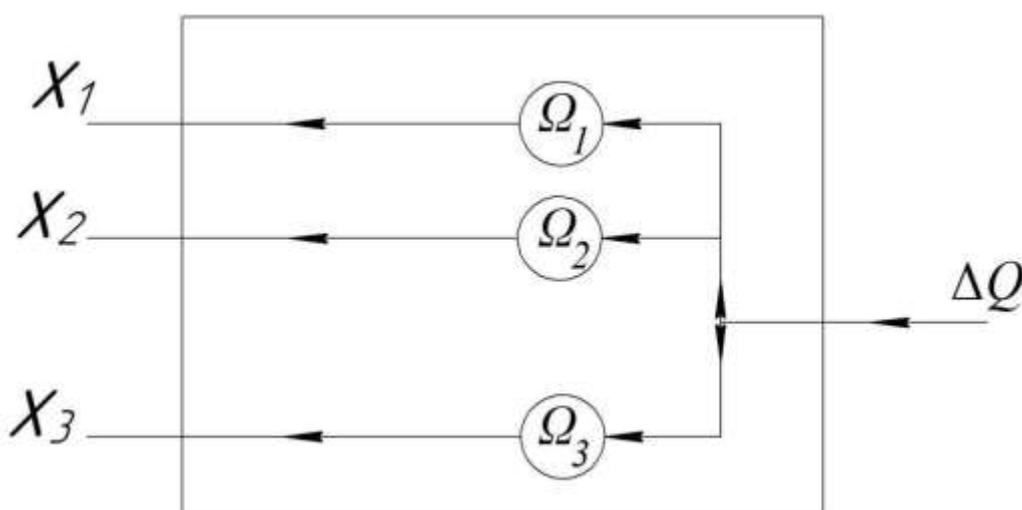

Fig.1.2. Structural diagram of the automaton optimizer



"KELAJAK TEKNOLOGIYALARI VA SUN'IY INTELLEKT"
nomli respublika ilmiy-amaliy masofaviy konferensiyasi
VOLUME-1, ISSUE-2, 2026

The optimization method is based on the M. L. Tsetlin automaton, which is the simplest element with an internal state that changes under the influence of the external environment in accordance with primitive reactions such as "yes-no", "acceptable-unacceptable", "pleasure-displeasure". Tsetlin's automaton has a memory depth of m and changes internal states in accordance with the graph (Fig. 1.1). The left states of the automaton correspond to negative actions of the automaton, the right ones - positive. The change of states of the automaton occurs according to the direction of the arrows: solid - with a positive reaction of the automaton to the state of the environment and dotted - with a negative reaction. If the automaton is stochastic, then the change of states occurs with a probability p with a positive reaction and a probability $q < p$ in case of a negative reaction.

An automaton optimizer composed of stochastic automata acquires the ability to search for the extremum of functions . both simple and with ravines and several extrema. Studies of the search efficiency of such an optimizer have shown that it decreases with an increase in the dimension of the objective function, while the accuracy of the optimal search increases with an increase in the memory depth of the automata. The dependence of the actual time spent on the optimal search on the memory depth depends on the number of variables and increases significantly only when $n \geq 5$. The spread of the search increases with a decrease in the probability p and is not limited when $p > 0.5$. This phenomenon allows, by increasing or decreasing the probability from 1.0 to 0.5 in accordance with the a priori

dissatisfaction or satisfaction of the search, to search for a global minimum in the presence of several local ones.

The ability of the stochastic automaton optimizer to find a minimum is not impaired even when random errors occur in determining the values of the objective function. In this case, interference filtering is achieved due to the presence of memory in the



“KELAJAK TEKNOLOGIYALARI VA SUN’IY INTELLEKT”
nomli respublika ilmiy-amaliy masofaviy konferensiyasi
VOLUME-1, ISSUE-2, 2026

automata.

The stochastic automaton optimizer is capable of solving complex problems: such as optimizing dynamic objects, stabilizing an unstable object, and finding the optimal structure of a slot machine.

The stochastic automaton optimizer has significant advantages over other optimal search methods. Firstly, due to the parallel operation of the automata, the optimal search time is reduced several times. Secondly, the reliability of the automaton method is much higher than that of existing optimization methods, since individual failures in the operation of the automata are equivalent to some change in the probability p and do not change anything in the search procedure. Thirdly, the automaton optimizer works well under conditions of nonlinearity of the constraints on the non-additivity of the objective function, which is a significant difficulty when using the linear and dynamic programming methods currently used to calculate optimal rolling modes.

Much attention is paid to the development of algorithms for calculating optimal rolling modes, especially after equipping mills with automatic control systems.

The main essence of the algorithms for optimizing rolling modes is the choice of the objective function and the mathematical apparatus for finding its extremum. In the overwhelming majority of existing works, the additive criterion is adopted as the objective function - the rolling cycle time, and the dynamic programming method is adopted as the optimization apparatus. However, this method, being a powerful optimization tool, has a number of shortcomings, consisting, firstly, of the difficulty of approaching multidimensional problems, and secondly, of fulfilling the conditions of additivity of the absurd function and linearity of the constraints. These conditions of the dynamic programming method force us to simplify the objective function, taking into account either the rolling time or the energy costs for rolling.

In the work, the method of conjugate with the method of penalty functions is used



“KELAJAK TEKNOLOGIYALARI VA SUN’IY INTELLEKT”
nomli respublika ilmiy-amaliy masofaviy konferensiyasi
VOLUME-1, ISSUE-2, 2026

as a mathematical apparatus of optimization. However, the method of conjugate requires the convexity of the objective function, its algorithm is complex near nonlinear boundaries and requires more search time. In other studies, the method of a mathematical model of the process is used, which, naturally, affects the decrease in the accuracy of calculations. In addition, like the method of dynamic programming, linear programming requires linearity of restrictions.

Methods of optimal control theory can be applied to solve problems of optimizing motion that is described by partial differential equations. Such problems are called distributed parameter problems.

When developing OMD technology, it is often necessary to solve the problem of distributing deformations by passes during rolling, by draws during drawing, in order to ensure maximum productivity while satisfying a number of restrictions that

ensure obtaining high-quality products. Let us solve one of these optimization problems.

The problem of optimal distribution of deformations between dies of multiple wires of a drawing machine with sliding turned out to be a problem of convex programming. It has a single optimum point, which can be found by a direct method by some minimization.

Let's try to find those objects of blooming, the optimization of which can be implemented. Apparently, that part of the technology, which is connected with mechanical movement of the processed metal and tool, can be the object of consideration for the purpose of optimization. Almost all movement of the technology is connected with mechanical movement. The exception is heating of metal before rolling in wells and cleaning of rolled products after rolling on fire cleaning machines, in these cases optimization is possible.

Conclusions



“KELAJAK TEKNOLOGIYALARI VA SUN’IY INTELLEKT”
nomli respublika ilmiy-amaliy masofaviy konferensiyasi
VOLUME-1, ISSUE-2, 2026

Fundamental knowledge of rolling is essential for practical use in the design of processing technologies for non-ferrous metals and alloys. The provided equations for evaluating deformation and energy-force parameters are applied in determining reduction schedules for sheets, strips, and tapes. The key energy-force characteristics of rolling that must be assessed when selecting a rolling mill are rolling force and torque.

During cold rolling of thin sheets and strips made of hard alloys, elastic deformation (flattening) of both the rolls and the strip occurs, while lateral spreading can be neglected. The efficiency of the rolling process is determined by mill productivity, material yield, and the quality of the final rolled product.

List of Literature

1. Kolesnikov A.G., Yakovlev R.A. Calculation and study of stresses and deformations of rolling mill frames. Study guide. - M.: Publishing house of Bauman Moscow State Technical University. 2005. - 55 p.

2. Pronikov A.S. Parametric reliability of machines. - M.: Publ. MSTU. 2002. - 560 p.

3. Yakovlev R.A. Fatigue strength and durability of rolling mill parts. Study guide. - M.: MSTU, 2000. - 44 p.

4. Rudskoy A. I., Lunev V. A. Theory and technology of rolling production. Study guide. - St. Petersburg: Nauka, 2008. - 507 p.

5. Kolesnikov A.G. Technological equipment for rolling production: a tutorial / A.G. Kolesnikov, R.A. Yakovlev, A.A. Maltsev. - M.: Publishing house of Bauman Moscow State Technical University, 2014. - 158 p.



“KELAJAK TEXNOLOGIYALARI VA SUN’IY INTELLEKT”
nomli respublika ilmiy-amaliy masofaviy konferensiyasi
VOLUME-1, ISSUE-2, 2026

Data Privacy Issues in the Use of Artificial Intelligence in International Arbitration and Mediation (On the Example of GDPR Requirements)

Qahhorova Durdona Ulug‘bek qizi

Master’s Student, International Commercial Law Program Tashkent State University
of Law

Abstract: This thesis analyzes, from the perspective of private international law, the data privacy issues arising from the utilization of artificial intelligence tools in international arbitration and mediation proceedings. The systemic conflict between the territorial scope of the European Union’s Regulation 2016/679 (GDPR) and the principle of confidentiality in international arbitration is examined. A comparative analysis of the regulatory frameworks and practices of the European Union, the United Kingdom, and Germany is conducted. Furthermore, the paper highlights potential challenges pertaining to the recognition and enforcement of AI-assisted arbitral awards under the 1958 New York Convention and the UNCITRAL Model Law. Specific recommendations for the amendment and enhancement of the legislation of the Republic of Uzbekistan are proposed.

Keywords: Artificial Intelligence, International Arbitration, Mediation, GDPR, Data Privacy, New York Convention, Conflict of Laws, EU AI Act, Cybersecurity.

XALQARO ARBITRAJ VA MEDIATSIYADA SUN’IY INTELLEKTDAN FOYDALANISHDA MA’LUMOTLAR MAXFIYLIGI MUAMMOLARI (GDPR TALABLARI MISOLIDA)

Toshkent davlat yuridik universiteti Xalqaro tijorat huquqi yo‘nalishi magistranti

Qahhorova Durdona Ulug‘bek qizi

E-mail: durdonakahhorova0135@gmail.com durdona.kahhorova@uetconstruction.com



“KELAJAK TEKNOLOGIYALARI VA SUN’IY INTELEKT”
nomli respublika ilmiy-amaliy masofaviy konferensiyasi
VOLUME-1, ISSUE-2, 2026

Annotatsiya: Tezisdagi xalqaro arbitraj va mediatsiya jarayonlarida sun’iy intellekt vositalaridan foydalanishda yuzaga keladigan ma’lumotlar maxfiyligi muammolari xalqaro xususiy huquq nuqtai nazaridan tahlil qilinadi. Yevropa Ittifoqining 2016/679-sonli Reglamenti (GDPR) hududiy ta’sir doirasi va xalqaro arbitrajdagi maxfiylik tamoyili o’rtasidagi tizimli ziddiyat o’rganiladi. Yevropa Ittifoqi, Buyuk Britaniya va Germaniya tajribasi qiyosiy tahlil qilinadi. Sun’iy intellekt yordamida qabul qilingan qarorlarni 1958-yilgi Nyu-York konvensiyasi va UNCITRAL na’munaviy qonuni doirasida tan olish va ijro etish bilan bog‘liq yuzaga kelishi mumkin bo‘lgan muammolar yoritiladi. O‘zbekiston Respublikasi qonunchiligini takomillashtirish bo‘yicha aniq takliflar ishlab chiqiladi.

Kalit so‘zlar: sun’iy intellekt, xalqaro arbitraj, mediatsiya, GDPR, ma’lumotlar maxfiyligi, Nyu-York konvensiyasi, kollizion normalar, EU AI Act, kiberxavfsizlik.

Аннотация: В данных тезисах с точки зрения международного частного права анализируются проблемы конфиденциальности данных, возникающие при использовании инструментов искусственного интеллекта в процессах международного арбитража и медиации. Исследуется системный конфликт между территориальной сферой действия Регламента ЕС 2016/679 (GDPR) и принципом конфиденциальности в международном арбитраже. Проводится сравнительный анализ опыта Европейского Союза, Великобритании и Германии. Освещаются потенциальные проблемы, связанные с признанием и приведением в исполнение решений (арбитражных решений), вынесенных с помощью искусственного интеллекта, в рамках Нью-Йоркской конвенции 1958 года и Типового закона ЮНСИТРАЛ. Разрабатываются конкретные предложения по совершенствованию законодательства Республики Узбекистан.

Ключевые слова: искусственный интеллект, международный арбитраж, медиация, GDPR, конфиденциальность данных, Нью-Йоркская конвенция,



“KELAJAK TEKNOLOGIYALARI VA SUN’IY INTELLEKT”
nomli respublika ilmiy-amaliy masofaviy konferensiyasi
VOLUME-1, ISSUE-2, 2026

КОЛЛИЗИОННЫЕ НОРМЫ, EU AI Act, кибербезопасность.

Kirish. Raqamli iqtisodiyot va sun’iy intellekt (keyingi o‘rinlarda – SI) texnologiyalarining jadal rivojlanishi xalqaro tijorat arbitraji va mediatsiya jarayonlarini tubdan o‘zgartirmoqda. SI vositalari hujjatlarni avtomatik tahlil qilish (Technology-Assisted Review), tahminiy analitika (predictive analytics), elektron dalillarni yig‘ish (e-discovery), ko‘p tilli avtomatik tarjima va qaror loyihalarini tayyorlashda keng qo‘llanilmoqda. SI texnologiyalarining 2022-yildan boshlab faol rivojlanishi esa hatto qaror loyihalarini ishlab chiqishda ham qo‘llanilish imkoniyatini yaratdi.

Biroq SI vositalarining ishlash mohiyati ulkan hajmdagi ma’lumotlarni, jumladan, jismoniy shaxslarga doir shaxsiy ma’lumotlarni qayta ishlashga asoslangani sababli, xalqaro arbitrajda bunday ma’lumotlar bir nechta yurisdiksiyalar bo‘ylab harakatlanadi va Yevropa Ittifoqining 2016/679-sonli Umumiy ma’lumotlarni himoya qilish reglamenti (GDPR) [1] talablari bilan kollizion munosabatga kirishadi. Mavzuning dolzarbligi GDPRning 3-moddasiga muvofiq belgilanadigan hududiy ta’siri tufayli O‘zbekiston hududidagi arbitraj institutlariga ham bevosita qo‘llanilishi bilan izohlanadi. Mazkur tezisning maqsadi transchegaraviy xalqaro arbitraj va mediatsiyada SI qo‘llanilishi natijasida vujudga keladigan ma’lumotlar maxfiyligi muammolarini xalqaro xususiy huquq nuqtai nazaridan tahlil qilish va O‘zbekiston qonunchiligini takomillashtirish bo‘yicha takliflar ishlab chiqishdan iborat.

1. Xalqaro huquqiy amaliyot. Yevropa Ittifoqi GDPR va 2024-yil 13-iyundagi 2024/1689-sonli Sun’iy intellekt to‘g‘risidagi reglament (EU AI Act) [2] bilan SI sohasidagi eng rivojlangan tartibga solish modeliga ega. EU AI Aktining III ilovasining 8(a)-bandiga muvofiq, adliya organlariga huquq normalarini aniq holatlarga tatbiq etishda yordamlashish va muqobil nizolarni hal qilish vositasida qo‘llaniladigan SI tizimlari yuqori xavfli (high-risk) deb tasniflanadi va ularga inson nazorati (14-modda), shaffoflik (13-modda), ma’lumotlar boshqaruvi (10-modda) hamda texnik hujjatlash



“KELAJAK TEXNOLOGIYALARI VA SUN’IY INTELEKT”
nomli respublika ilmiy-amaliy masofaviy konferensiyasi
VOLUME-1, ISSUE-2, 2026

(11-modda) bo‘yicha qat’iy talablar qo‘llaniladi. Yevropa Adliya Sudining 2020-yil 16-iyuldagi C-311/18-sonli Schrems II ishi[3] ma’lumotlarni qabul qiluvchi davlatda himoya darajasining muvofiqligini (adequacy) har bir holatda alohida baholash majburiyatini yukladi. Bu O‘zbekiston kabi himoya darajasi yetarli deb topilmagan davlatlardagi arbitraj institutlari uchun standart shartnoma bandlariga (SCCs) qo‘shimcha ravishda maxsus texnik xavfsizlik choralarini joriy etishni talab qiladi.

Buyuk Britaniyada 2021-yil aprel oyida “Raqamli nizolarni hal qilish qoidalari”ning (Digital Dispute Resolution Rules) [4] qabul qilinishi sun’iy intellekt (SI) yordamida nizolarni hal etishning huquqiy maqomini belgilashda muhim qadam bo‘ldi. Shuningdek, Buyuk Britaniya Oliy sudining *Halliburton* [5] ishi bo‘yicha qarorida arbitrning xolislikni ta’minlash borasidagi oshkoralik majburiyati keng izohlangan bo‘lib, ushbu yondashuvni arbitrajda SI vositalarini qo‘llash natijasida yuzaga kelishi mumkin bo‘lgan manfaatlar to‘qnashuvini oshkor etish majburiyatiga ham qiyosiy (analogiya sifatida) tatbiq etish maqsadga muvofiqdir.

Bu borada Germaniya tajribasi ham alohida ahamiyat kasb etadi. Germaniya Umumiy ma’lumotlarni himoya qilish reglamentini (GDPR) Federal ma’lumotlarni himoya qilish to‘g‘risidagi qonun [6] orqali milliy huquq tizimiga implementatsiya qilgan. Germaniya Fuqarolik protsessual kodeksining 1025–1066-paragraflari UNCITRAL Namunaviy qonuniga asoslanib arbitraj jarayonlarini tartibga solsa, 1059-paragrafida arbitraj qarorlarini bekor qilish asosi sifatida ommaviy tartib (public policy) qoidasi qat’iy belgilangan. Germaniya Arbitraj Instituti (DIS) ning 2018-yilgi Reglamenti [7] raqamli hujjatlar aylanmasi va jarayon samaradorligini ta’minlashga qaratilgan bo‘lib, hozirgi zamon huquqiy doktrinasida ma’lumotlar himoyasi qoidalarining qo‘pol ravishda buzilishi ommaviy tartibning (public policy) buzilishi sifatida baholanishi mumkinligi o‘z tasdig‘ini topgan. Xalqaro miqyosdagi huquqiy o‘zgarishlarga kelsak, 2024-yil 17-mayda qabul qilinib, sentabr oyida Vilnyusda



“KELAJAK TEKNOLOGIYALARI VA SUN’IY INTELLEKT”
nomli respublika ilmiy-amaliy masofaviy konferensiyasi
VOLUME-1, ISSUE-2, 2026

imzolash uchun ochilgan Yevropa Kengashining “Sun’iy intellekt, inson huquqlari, demokratiya va qonun ustuvorligi to‘g‘risida”gi Ramka konvensiyasi (CETS No. 225) [8] SI sohasidagi ilk xalqaro huquqiy majburiy hujjatga aylandi. Bunga parallel ravishda, nizolarni muqobil hal etish tizimida 2019-yilgi Singapur konvensiyasi [9] xalqaro mediatsiya kelishuvlari ijrosini ta’minlovchi yangi mexanizmni amaliyotga joriy qildi. Sohadagi jarayonlarni tartibga soluvchi yetakchi doktrinal va “yumshoq huquq” (soft law) manbalari sirasiga ICCA-IBA ning “Xalqaro arbitrajda ma’lumotlarni himoya qilish bo‘yicha yo‘l xaritasi” [10], ICCA-NYC Bar-CPR ning “Xalqaro arbitrajda kiberxavfsizlik bo‘yicha protokoli” [12] hamda Kremniy vodiysi Arbitraj va mediatsiya markazi (SVAMC) tomonidan 2024-yil aprel oyida e‘lon qilingan “Arbitrajda sun’iy intellektdan foydalanish bo‘yicha ko‘rsatmalar”i [11] kiradi. Ushbu hujjatlar raqamli texnologiyalarni arbitrajga integratsiya qilishda fundamental ahamiyatga ega. Institutsional darajada ICC ning 2021-yil 1-yanvardan kuchga kirgan Tomonlar va Arbitraj tribunallari uchun ko‘rsatmasi [13] kiberxavfsizlik va elektron hujjat aylanishi masalalarini batafsil tartibga soldi. London Xalqaro Arbitraj Sudining (LCIA) 2020-yil reglamentining 30A-moddasi [14] ma’lumotlar himoyasi va GDPR talablariga rioya qilish majburiyatini bevosita mustahkamlaydi.

2. Xalqaro xususiy huquqiy muammolar. Xalqaro arbitrajda sun’iy intellektdan (SI) foydalanish bir qator xalqaro xususiy huquqiy muammolarni yuzaga keltiradi. Birinchi muammo bu kollizion normalar to‘qnashuvi. Xalqaro arbitraj jarayonida bir vaqtning o‘zida bir nechta huquqiy tartibotlarning o‘zaro raqobati kuzatiladi: taraflar tanlagan moddiy huquq (*lex contractus*), arbitraj o‘tkaziladigan joy huquqi (*lex arbitri*), arbitraj qarori ijro etiladigan davlat qonunchiligi (*lex executionis*) hamda ma’lumotlar himoyasiga doir maxsus tartibga solish rejimlari (xususan, GDPRning hududiy ta’siri). Ma’lumotlarni himoya qilish qoidalari o‘ta muhim imperativ xususiyatga ega bo‘lib, ularni taraflarning kelishuvi bilan istisno qilib bo‘lmaydi. Ikkinchi muammo SI



“KELAJAK TEKNOLOGIYALARI VA SUN’IY INTELLEKT”
nomli respublika ilmiy-amaliy masofaviy konferensiyasi
VOLUME-1, ISSUE-2, 2026

ishtirokida qabul qilingan qarorlarni 1958-yilgi Nyu-York konvensiyasi [15] doirasida tan olish va ijro etish masalasi. Konvensiyaning V(2)(b)-moddasida arbitraj qarorini rad etish asosi sifatida ommaviy tartibga (public policy) zidlik ko‘rsatilgan. Yevropa Ittifoqi va Germaniya sudlari amaliyotida GDPRning fundamental tamoyillari qo‘pol ravishda buzilishi aynan ommaviy tartibning buzilishi sifatida baholanishi o‘z tasdig‘ini topgan. Shuningdek, Konvensiyaning V(1)(b)-moddasi tarafning arbitraj jarayonida o‘z dalillarini taqdim eta olmasligini ya’ni due process buzilishi qarorni bekor qilish asosi sifatida belgilaydi. Agar SI vositasi yakuniy qarorga hal qiluvchi ta’sir ko‘rsatgan bo‘lsa-yu, biroq taraflar bu haqida tegishli tartibda xabardor qilinmagan bo‘lsa, aynan ushbu modda qo‘llanilishi mumkin. Singapur konvensiyasining 5-moddasi ham xalqaro mediatsiya kelishuvlarini tan olishni rad etishda xuddi shunday huquqiy asoslarni taqdim etadi. Uchinchi muammo GDPRning 22-moddasi orqali to‘liq avtomatlashtirilgan qarorlar qabul qilishga o‘rnatilgan cheklolardir. Unga ko‘ra, ma’lumot subyekti faqat avtomatlashtirilgan qayta ishlashga asoslangan va o‘zi uchun huquqiy oqibatlar keltirib chiqaradigan qarorga bo‘ysunmaslik huquqiga ega. Shu bilan birga, UNCITRAL Na’munaviy qonunining [16] 18-moddasida kafolatlangan taraflarning tengligi va o‘z pozitsiyasini taqdim etish imkoniyati tamoyili arbitrning qaror qabul qilish funksiyasini to‘g‘ridan-to‘g‘ri SI tizimiga topshirishni istisno qiladi. SVAMC ko‘rsatmalarida [11] ham ushbu omil inobatga olinib, SI vositalariga ishonib topshirilishi mumkin bo‘lmagan *non-delegable functions* qat’iy belgilab qo‘yilgan. To‘rtinchi muammo arbitraj maxfiyligi hamda ma’lumot subyekti huquqlari o‘rtasidagi ziddiyat. Arbitraj jarayonining bazaviy maxfiylik tamoyili GDPRning 15–21-moddalarida kafolatlangan ma’lumot subyektining huquqlari ma’lumot olish (15-modda), tuzatish kiritish (16-modda), o‘chirish yoki “unutilish huquqi” (17-modda), qayta ishlashni cheklash (18-modda) va e’tiroz bildirish (21-modda) huquqlari bilan to‘qnashadi. Ushbu muammo arbitraj arxivlarida uzoq muddat saqlanadigan hujjatlarga



“KELAJAK TEXNOLOGIYALARI VA SUN’IY INTELLEKT”
nomli respublika ilmiy-amaliy masofaviy konferensiyasi
VOLUME-1, ISSUE-2, 2026

nisbatan yanada dolzarblashadi. ICCA-IBA Yo‘l xaritasi [10] bunday ziddiyatlarni ma’lumotlarni minimallashtirish, ma’lumot yig‘ish maqsadini cheklash hamda mutanosiblik testini qo‘llash orqali muvozanatga keltirishni tavsiya qiladi.

Beshinchi muammo arbitrning xolisligi va kiberxavfsizlik tahdidlari. IBAning “Xalqaro arbitrajda manfaatlar to‘qnashuvi bo‘yicha ko‘rsatmalari”ga [17] muvofiq, arbitr o‘ziga ma’lum bo‘lgan har qanday manfaatlar to‘qnashuvini oshkor qilishi shart. SI vositalari qo‘llanilganda, bu majburiyat arbitrning ma’lum bir SI tizimini ishlab chiquvchi kompaniya bilan moliyaviy yoki kasbiy aloqalarini oshkor etishini ham qamrab oladi. Bunga qo‘shimcha ravishda, bulutli texnologiyalarga (cloud-based) asoslangan SI platformalaridan foydalanish ma’lumotlarning maxfiyligi va butunligiga tahdid soluvchi texnik xavflarni tug‘diradi. Xususan, ICCA-NYC Bar-CPR Protokoli [12] bunday xavflar sirasiga sun‘iy intellekt modelini o‘qitish (trening) jarayonida kiritilgan maxviy ma’lumotlarning oqib chiqishi, model inversiyasi hujumlari va uchinchi shaxs provayderlari tomonidan ma’lumotlardan ruxsatsiz foydalanish holatlarini kiritadi.

3. O‘zbekiston huquq tizimi bilan qiyosiy tahlil. O‘zbekiston Respublikasida mazkur sohadagi munosabatlarni tartibga solishda quyidagi asosiy qonun hujjatlari amal qiladi: UNCITRAL Namunaviy qonuni asosida ishlab chiqilgan “Xalqaro tijorat arbitraji to‘g‘risida”gi Qonun [18], “Mediatsiya to‘g‘risida”gi Qonun [19], “Shaxsga doir ma’lumotlar to‘g‘risida”gi Qonun [20] hamda Fuqarolik protsessual kodeksi. Ta’kidlash joizki, O‘zbekiston 1996-yilda 1958-yilgi Nyu-York konvensiyasiga qo‘shilgan, biroq xalqaro mediatsiya kelishuvlari ijrosini ta’minlovchi Singapur konvensiyasini hozircha imzolamagan. Biroq O‘zbekiston Respublikasining Yevropa Kengashining 2024-yilgi SI bo‘yicha Ramka konvensiyasini (CETS No. 225) imzolashi hamda 2019-yilgi Singapur konvensiyasini ratifikatsiya qilish istiqbollari jiddiy ko‘rib chiqish arbitraj va mediatsiya sohasi uchun ijobiy o‘zgarishlar oli kelgan bo‘lar edi.



“KELAJAK TEKNOLOGIYALARI VA SUN’IY INTELLEKT”
nomli respublika ilmiy-amaliy masofaviy konferensiyasi
VOLUME-1, ISSUE-2, 2026

O‘tkazilgan qiyosiy tahlilda milliy qonunchilikda SI va ma’lumotlar himoyasi bo‘yicha quyidagi huquqiy va tizimli bo‘shliqlarni aniqlandi: Birinchidan, “Shaxsga doir ma’lumotlar to‘g‘risida”gi qonunda GDPRning 22-moddasiga muqobil bo‘lgan, ya’ni shaxsning faqat avtomatlashtirilgan qarorga bo‘ysunmaslik huquqini kafolatlovchi maxsus norma mavjud emas. Bu O‘zbekistondagi arbitraj institutlari SI tizimlaridan foydalanganda, inson aralashuvi va nazorati qanchalik majburiy ekanligi bo‘yicha aniq mezonlarning yo‘qligiga olib keladi. Ikkinchidan, “Xalqaro tijorat arbitraji to‘g‘risida”gi qonun faqat an’anaviy arbitraj jarayonlariga moslashtirilgan bo‘lib, SI vositalarini qo‘llash, ulardan foydalanilganligini oshkor etish majburiyati hamda arbitrning SI yordamida qaror loyihalarini tayyorlash kabi zamonaviy masalalarni qamrab olmagan. Shu jumladan, Toshkent Xalqaro Arbitraj Markazi (TIAC) Reglamentida ham bu borada aniq tartibga soluvchi mexanizmlar shakllantirilmagan.

Uchinchidan, xalqaro miqyosda onlayn nizolarni hal qilish (ODR - Online Dispute Resolution) tizimi jadal rivojlanayotgan bir paytda, “Mediatsiya to‘g‘risida”gi qonunda onlayn va SI yordamidagi mediatsiya jarayonlari to‘liq tartibga solinmagan. To‘rtinchidan, “Shaxsga doir ma’lumotlar to‘g‘risida”gi qonun O‘zbekiston fuqarolariga oid shaxsiy ma’lumotlarni faqat respublika hududida joylashgan serverlarda saqlashni talab etadi. Aksariyat xalqaro SI platformalari Yevropa, AQSh yoki xorijiy Osiyo serverlariga tayanadigan transchegaraviy xalqaro arbitrajda, bu qoida jiddiy to‘siq vazifasini o‘tashi mumkin. Beshinchidan, milliy sud amaliyotida ommaviy tartib (public policy) doktrinasini SI va ma’lumotlarni himoya qilish konsepsiyalari nuqtai nazaridan sharhlovchi sud pretsedentlari yoki Oliy sudning hali to‘liq rasmiy tushuntirishlari hali shakllanmagan.

Xulosa va takliflar. Olib borilgan tahlillar O‘zbekiston qonunchiligini jadal raqamlashtirish davri va xalqaro standartlarga moslashtirish zaruratini ko‘rsatadi. SI yordamida qabul qilingan arbitraj qarorlarining xorijiy yurisdiksiyalarda muammosiz



“KELAJAK TEXNOLOGIYALARI VA SUN’IY INTELLEKT”
nomli respublika ilmiy-amaliy masofaviy konferensiyasi
VOLUME-1, ISSUE-2, 2026

tan olinishini ta’minlash, transchegaraviy investitsiyalarni himoya qilish va TIACning xalqaro miqyosdagi nufuzini yanada mustahkamlash maqsadida quyidagi qonunchilik takliflari ilgari suriladi:

1. “Shaxsga doir ma’lumotlar to‘g‘risida”gi qonunni GDPRning 22-moddasi darajasidagi me’yor bilan to‘ldirish: ma’lumot subyektiga to‘liq avtomatlashtirilgan qarorga bo‘ysunmaslik, jarayonda inson aralashuvini talab qilish va SI tizimi qarorining mantiqiy asosini bilish huquqlarini taqdim etish.
2. “Xalqaro tijorat arbitraji to‘g‘risida”gi qonunga jarayonda SI vositalaridan foydalanilganligini majburiy oshkor qilish, arbitrning qaror qabul qilish vakolatini to‘g‘ridan-to‘g‘ri SIga topshirmaslik tamoyili va bazaviy kiberxavfsizlik standartlarini o‘zida aks ettirgan alohida modda kiritish.
3. “Mediatsiya to‘g‘risida”gi qonunni onlayn (ODR) va SI yordamidagi mediatsiya jarayonlarini tartibga soluvchi maxsus bob bilan boyitish, bunda SI-mediatorning funksional chegaralari va majburiyatlari doirasini qat’iy belgilash.
4. Toshkent Xalqaro Arbitraj Markazi (TIAC) uchun SVAMC ko‘rsatmalari, ICCA-IBA Yo‘l xaritasi va ICCA-NYC Bar-CPR kiberxavfsizlik protokoli andozasi asosida arbitrajda SI vositalaridan foydalanish bo‘yicha maxsus amaliy ko‘rsatmalar ishlab chiqish va amaliyotga joriy etish.
5. Ma’lumotlarning transchegaraviy erkin oqimini ta’minlash maqsadida Yevropa Ittifoqi bilan ikki tomonlama kelishuvlar tuzish choralarini ko‘rish. Bu kelajakda O‘zbekistonning Yevropa Komissiyasidan ma’lumotlar himoyasi bo‘yicha adekvatlik qarorini olishi uchun mustahkam zamin yaratadi.
6. O‘zbekiston Respublikasi Oliy sudi tomonidan Nyu-York konvensiyasining V(2)(b)-moddasi hamda milliy protsessual qonunchilikni qo‘llashda izchillikni ta’minlash uchun ommaviy tartib (public policy) tushunchasini SI xatarlari va



“KELAJAK TEXNOLOGIYALARI VA SUN'IY INTELLEKT”
nomli respublika ilmiy-amaliy masofaviy konferensiyasi
VOLUME-1, ISSUE-2, 2026

ma'lumotlar daxlsizligi nuqtai nazaridan keng sharhlovchi rasmiy tushuntirish (Plenum qarori) qabul qilish.

Xulosa qilib aytganda, ilgari surilayotgan mazkur takliflar O'zbekiston huquq tizimini nafaqat ilg'or xalqaro standartlarga uyg'unlashtirish, balki uni raqamli huquq hamda sun'iy intellekt boshqaruvi sohasidagi zamonaviy chaqiriqlarga to'liq moslashtirishga qaratilgandir. Ushbu kompleks chora-tadbirlar mamlakatimizda transchegaraviy arbitraj va mediatsiya institutlarining xalqaro nufuzi hamda ishonchliligini oshirish bilan bir qatorda, innovatsion texnologiyalarning ma'lumotlar daxlsizligi va adolat tamoyillariga qat'iy rioya etgan holda, faqatgina huquq ustuvorligiga xizmat qilishini kafolatlovchi mustahkam poydevor bo'lib xizmat qiladi.

Foydalanilgan adabiyotlar ro'yxati

1. Regulation (EU) 2016/679 of the European Parliament and of the Council of 27 April 2016 on the protection of natural persons with regard to the processing of personal data (General Data Protection Regulation), OJ L 119, 4.5.2016.

2. Regulation (EU) 2024/1689 of the European Parliament and of the Council of 13 June 2024 laying down harmonised rules on artificial intelligence (Artificial Intelligence Act), OJ L, 12.7.2024.

3. Case C-311/18, Data Protection Commissioner v Facebook Ireland Ltd and Maximillian Schrems (Schrems II), ECLI:EU:C:2020:559, Judgment of 16 July 2020.

4. UK Jurisdiction Taskforce, Digital Dispute Resolution Rules, April 2021.

5. Halliburton Company v Chubb Bermuda Insurance Ltd [2020] UKSC 48, Judgment of 27 November 2020.

6. Bundesdatenschutzgesetz (BDSG) vom 30. Juni 2017 (BGBl. I S. 2097).

7. Deutsche Institution für Schiedsgerichtsbarkeit (DIS), Arbitration Rules 2018.

8. Council of Europe Framework Convention on Artificial Intelligence and Human Rights, Democracy and the Rule of Law, CETS No. 225, Vilnius, 17 May 2024.



“KELAJAK TEXNOLOGIYALARI VA SUN’IY INTELLEKT”
nomli respublika ilmiy-amaliy masofaviy konferensiyasi
VOLUME-1, ISSUE-2, 2026

9. United Nations Convention on International Settlement Agreements Resulting from Mediation (Singapore Convention), Singapore, 7 August 2019.

10. ICCA-IBA Joint Task Force on Data Protection in International Arbitration, Roadmap to Data Protection in International Arbitration, March 2020.

11. Silicon Valley Arbitration & Mediation Center (SVAMC), Guidelines on the Use of Artificial Intelligence in Arbitration, Edition 1, April 2024.

12. ICCA-NYC Bar-CPR Working Group, Cybersecurity Protocol for International Arbitration, 2020 Edition.

13. International Chamber of Commerce, Note to Parties and Arbitral Tribunals on the Conduct of the Arbitration under the ICC Rules of Arbitration, 1 January 2021.

14. London Court of International Arbitration, LCIA Arbitration Rules (effective 1 October 2020), Article 30A.

15. Convention on the Recognition and Enforcement of Foreign Arbitral Awards (New York Convention), New York, 10 June 1958.

16. UNCITRAL Model Law on International Commercial Arbitration (1985, with amendments as adopted in 2006).

17. International Bar Association, IBA Guidelines on Conflicts of Interest in International Arbitration, 2024.

18. O‘zbekiston Respublikasining “Xalqaro tijorat arbitraji to‘g‘risida”gi Qonuni, 2021-yil 16-fevral, O‘RQ-674.

19. O‘zbekiston Respublikasining “Mediatsiya to‘g‘risida”gi Qonuni, 2018-yil 3-iyul, O‘RQ-482.

20. O‘zbekiston Respublikasining “Shaxsga doir ma’lumotlar to‘g‘risida”gi Qonuni, 2019-yil 2-iyul, O‘RQ-547.



*Essential Pedagogical Competences for University English Language Teachers in
Uzbekistan: Moving Toward More Effective and Modern Teaching Practices*

Mukhlisa Odilova

Yangi Asr University Language Department, English Language Instructor

Email: muhlissodilova@gmail.com

Abstract

In Uzbekistan, the demand for high-quality English language education at the university level has increased significantly in recent years. This situation requires teachers to develop not only language proficiency but also strong pedagogical competences. This article explores the key competences that university English teachers in Uzbekistan should have, with a focus on adopting more effective and modern teaching practices. Based on a qualitative literature review, the study highlights areas such as lesson planning, interactive teaching methods, assessment literacy, and reflective practice. The findings suggest that teachers need to move beyond traditional teacher-centered instruction and adopt more learner-centered approaches. As Borg (2018) explains, teachers’ beliefs strongly influence their classroom practices. At the same time, Mann and Walsh (2017) emphasize the importance of reflection in improving teaching quality.

Keywords: Pedagogical competence, Uzbekistan, university teaching, English language teachers, modern methods, reflective practice

Introduction

In recent years, Uzbekistan has made significant efforts to improve English language education, especially at the university level. However, many classrooms still rely on traditional teaching methods, where the teacher speaks most of the time and students remain passive. This creates a gap between current teaching practices and modern international standards. Pedagogical competence plays a key role in solving this



“KELAJAK TEKNOLOGIYALARI VA SUN’IY INTELLEKT”
nomli respublika ilmiy-amaliy masofaviy konferensiyasi
VOLUME-1, ISSUE-2, 2026

issue. It includes the ability to plan lessons, use effective teaching methods, manage classrooms, and assess students properly. According to Borg (2018), teachers’ knowledge and beliefs directly influence how they teach. In the context of Uzbekistan, this means that improving teacher competence can lead to better learning outcomes.

At the same time, Mann and Walsh (2017) argue that teachers should reflect on their teaching and continuously improve. This is especially important when trying to introduce more modern and effective approaches.

The purpose of this study is to identify the key pedagogical competences that university English teachers in Uzbekistan should develop and to explain how these competences can support more modern, learner-centered teaching. As Leung (2016) suggests, teaching should always respond to the needs of the context, which in this case includes educational reforms and global expectations.

Methods

This study uses a qualitative literature review to explore pedagogical competences and modern teaching practices. Recent academic sources published after 2015 were selected to ensure that the discussion reflects current developments in language teaching.

The data were collected from books and articles related to:

- *English language teaching*
- *teacher development*
- *modern and communicative methodologies*

Walsh (2019) explains that classroom interaction is a key element of effective teaching, especially in language learning. Similarly, Nation and Macalister (2020) highlight the importance of planning and adapting teaching to learners’ needs.

The data were analyzed using a thematic approach, focusing on key competences such as instructional skills, teaching methods, classroom management, and assessment.



“KELAJAK TEKNOLOGIYALARI VA SUN’IY INTELLEKT”
nomli respublika ilmiy-amaliy masofaviy konferensiyasi
VOLUME-1, ISSUE-2, 2026

This approach allows for a clear understanding of how these competences can be applied in the Uzbekistan university context.

Discussion. The findings show that university English teachers in Uzbekistan need to strengthen several important pedagogical competences in order to teach more effectively and in a modern way.

First, instructional competence is essential. Teachers should plan lessons with clear objectives and include activities that encourage student participation. According to Nation and Macalister (2020), good lesson design supports meaningful learning. However, in many Uzbek classrooms, lessons are still teacher-centered, so there is a need to shift toward more interactive approaches (Leung, 2016).

Second, methodological competence is crucial. Teachers should use modern teaching methods such as group work, discussions, and task-based learning. Walsh (2019) emphasizes that interaction helps students develop real communication skills. Moving away from memorization toward communication is an important step for improvement. Third, classroom management should support active learning. Instead of focusing only on discipline, teachers should create a comfortable environment where students feel confident to speak and participate.

Another key area is assessment literacy. Teachers need to use assessment not only to give grades but also to support learning. Fulcher (2018) highlights that effective assessment includes clear criteria and constructive feedback. This is especially important in university settings where academic standards are high.

Finally, reflective practice is necessary for continuous improvement. Teachers should think about their lessons and identify what works and what needs to change. Mann and Walsh (2017) argue that reflection helps teachers move toward more effective teaching. In addition, Borg (2018) suggests that awareness of teaching practices leads to better decisions in the classroom.



“KELAJAK TEKNOLOGIYALARI VA SUN’IY INTELLEKT”
nomli respublika ilmiy-amaliy masofaviy konferensiyasi
VOLUME-1, ISSUE-2, 2026

Overall, the discussion shows that adopting more modern and effective teaching practices in Uzbekistan requires both skill development and a change in mindset.

Conclusion

This study explored the pedagogical competences that university English language teachers in Uzbekistan need in order to improve their teaching. The findings show that effective teaching depends on a combination of lesson planning, teaching methods, classroom management, assessment, and reflection.

One important conclusion is that teachers should move away from traditional, teacher-centered methods and adopt more modern, learner-centered approaches. As Borg (2018) explains, changes in teaching practices begin with changes in teachers’ beliefs. Similarly, Mann and Walsh (2017) highlight that continuous reflection is necessary for professional growth.

In the context of Uzbekistan, improving pedagogical competence is essential for meeting international standards and preparing students for global communication. Future research could focus on how teacher training programs can better support this transition to more effective and modern teaching.

References

1. Borg, S. (2018). *Teacher cognition and language education: Research and practice*. Bloomsbury.
2. Fulcher, G. (2018). *The assessment of second language learners*. Routledge.
3. Leung, C. (2016). *English as an additional language: A close-to-practice perspective*. *Language and Education*, 30(1), 1–3.
4. Mann, S., & Walsh, S. (2017). *Reflective practice in English language teaching: Research-based principles and practices*. Routledge.
5. Nation, I. S. P., & Macalister, J. (2020). *Language curriculum design (2nd ed.)*. Routledge.



“KELAJAK TEXNOLOGIYALARI VA SUN’IY INTELLEKT”
nomli respublika ilmiy-amaliy masofaviy konferensiyasi
VOLUME-1, ISSUE-2, 2026

ANALYTICAL INSTRUMENTS AND MODERN APPROACHES IN MANAGING FINANCIAL STABILITY

Nao‘betova Ziyada Niyet qizi

2nd-year Basic Doctoral Student Tashkent State University of Economics

Abstract.

This thesis examines analytical instruments and modern approaches used in managing the financial stability of enterprises. During the research, classical financial analysis methods, bankruptcy prediction models, risk assessment instruments, and the role of modern digital technologies in financial management were analyzed. In addition, the advantages of using econometric modeling, stress-testing mechanisms, and business analytics systems in financial stability management were highlighted. The study substantiates that ensuring financial stability in enterprises should not be limited only to monitoring financial indicators, but must also be closely connected with early risk identification and the analytical justification of management decisions.

Keywords:

financial stability, financial analysis, analytical instruments, risk management, bankruptcy model, stress test, business analytics, econometric modeling, liquidity, profitability.

MOLIYAVIY BARQARORLIKNI BOSHQARISHDA ANALITIK INSTRUMENTLAR VA ZAMONAVIY YONDASHUVLAR

Nao‘betova Ziyada Niyet qizi

TDIU, 2-kurs tayanch doktoranti

ANNOTATSIYA

Mazkur tezisdagi korxonalarining moliyaviy barqarorligini boshqarishda qo‘llaniladigan analitik instrumentlar va zamonaviy yondashuvlar tadqiq etilgan.



“KELAJAK TEKNOLOGIYALARI VA SUN’IY INTELLEKT”
nomli respublika ilmiy-amaliy masofaviy konferensiyasi
VOLUME-1, ISSUE-2, 2026

Tadqiqot davomida klassik moliyaviy tahlil usullari, bankrotlikni prognozlash modellari, risklarni baholash instrumentlari hamda zamonaviy raqamli texnologiyalarning moliyaviy boshqaruvdagi o‘rni tahlil qilindi. Shuningdek, moliyaviy barqarorlikni boshqarishda ekonometrik modellashtirish, stress-test mexanizmlari va biznes analitika tizimlaridan foydalanishning afzalliklari yoritildi. Tadqiqot natijasida korxonalarda moliyaviy barqarorlikni ta’minlash faqat moliyaviy ko‘rsatkichlarni nazorat qilish bilan cheklanmasligi, balki risklarni erta aniqlash va boshqaruv qarorlarini analitik asoslash bilan chambarchas bog‘liqligi asoslab berildi.

Kalit so‘zlar: moliyaviy barqarorlik, moliyaviy tahlil, analitik instrumentlar, risklarni boshqarish, bankrotlik modeli, stress-test, biznes analitika, ekonometrik modellashtirish, likvidlilik, rentabellik.

KIRISH

Bozor iqtisodiyoti sharoitida korxonalarining barqaror faoliyat yuritishi ko‘p jihatdan ularning moliyaviy holati va moliyaviy resurslarni samarali boshqarish darajasiga bog‘liq hisoblanadi. Iqtisodiy muhitdagi noaniqlik, inflyatsion jarayonlar, moliyaviy bozorlardagi tebranishlar hamda global iqtisodiy risklarning ortib borishi korxonalarda moliyaviy barqarorlikni boshqarish masalasining dolzarbligini yanada oshirmoqda.

So‘nggi yillarda moliyaviy boshqaruv tizimida raqamli texnologiyalar va analitik instrumentlardan foydalanish tendensiyasi kuchaymoqda. An’anaviy moliyaviy ko‘rsatkichlar bilan bir qatorda ekonometrik modellar, bankrotlikni prognozlash usullari, stress-test mexanizmlari hamda biznes analitika platformalari korxonalarining moliyaviy holatini chuqur tahlil qilish va ehtimoliy risklarni oldindan aniqlash imkonini bermoqda. Shu sababli moliyaviy barqarorlikni boshqarishda zamonaviy analitik instrumentlarning nazariy va amaliy jihatlarini o‘rganish muhim ilmiy-amaliy ahamiyatga ega.



“KELAJAK TEKNOLOGIYALARI VA SUN’IY INTELLEKT”
nomli respublika ilmiy-amaliy masofaviy konferensiyasi
VOLUME-1, ISSUE-2, 2026

Mazkur tezisning maqsadi moliyaviy barqarorlikni boshqarishda qo‘llaniladigan analitik instrumentlar va zamonaviy yondashuvlarning mazmunini yoritish hamda ularning korxonalar moliyaviy boshqaruvidagi ahamiyatini asoslashdan iborat. Moliyaviy barqarorlikni baholashda eng keng qo‘llaniladigan instrumentlar moliyaviy koeffitsientlar tizimi hisoblanadi. Ushbu yondashuv asosida korxonalarlik likvidlilik, to‘lov qobiliyati, rentabellik va moliyaviy mustaqillik darajasi tahlil qilinadi. Joriy likvidlilik koeffitsienti, moliyaviy leverage, aktivlar rentabelligi va kapital rentabelligi kabi ko‘rsatkichlar korxonalar moliyaviy holatini baholashda muhim ahamiyat kasb etadi. Mazkur yondashuvning afzalligi hisob-kitoblarning soddaligi va amaliyotda keng qo‘llanilishidadir. Biroq klassik ko‘rsatkichlar tizimi moliyaviy risklarning murakkab o‘zaro bog‘liqligini to‘liq aks ettira olmaydi. Shu sababli zamonaviy iqtisodiy sharoitda ushbu instrumentlarni boshqa analitik yondashuvlar bilan integratsiyalash zarurati yuzaga kelmoqda. Moliyaviy barqarorlikni boshqarishda bankrotlikni prognozlash modellari muhim analitik instrumentlardan biri hisoblanadi. Ushbu modellar korxonaning moliyaviy inqirozga uchrash ehtimolini oldindan aniqlash imkonini beradi. Mazkur yo‘nalishda E. Altman tomonidan ishlab chiqilgan Z-score modeli keng qo‘llaniladi. Ushbu model bir nechta moliyaviy ko‘rsatkichlarni yagona integral indeksga birlashtirish orqali korxonaning moliyaviy holatini baholash imkonini beradi. Keyinchalik Springate, Taffler va boshqa olimlar tomonidan ham turli modifikatsiyalar ishlab chiqilgan.

Bankrotlikni prognozlash modellari moliyaviy risklarni erta aniqlash imkonini bersa-da, ularning ayrimlari rivojlangan davlatlar iqtisodiyoti ma’lumotlari asosida ishlab chiqilgani sababli barcha tarmoqlar va iqtisodiy sharoitlarga to‘liq mos kelmasligi mumkin. So‘nggi yillarda moliyaviy barqarorlikni boshqarishda ekonometrik modellashtirish usullaridan foydalanish kengaymoqda. Mazkur yondashuv moliyaviy ko‘rsatkichlar o‘rtasidagi statistik bog‘liqliklarni aniqlash hamda ularning korxonalar



“KELAJAK TEKNOLOGIYALARI VA SUN’IY INTELLEKT”
nomli respublika ilmiy-amaliy masofaviy konferensiyasi
VOLUME-1, ISSUE-2, 2026

barqarorligiga ta’sirini baholash imkonini beradi. Shuningdek, stress-test mexanizmlari korxonalarining tashqi iqtisodiy shoklarga bardoshlilikini baholashda muhim ahamiyatga ega. Ushbu yondashuv orqali inflyatsiya, valyuta kursi yoki foiz stavkalari o‘zgarishi natijasida korxonaning moliyaviy holati qanday o‘zgarishi prognoz qilinadi. Stress-test mexanizmlari ayniqsa yuqori riskli tarmoqlarda moliyaviy xavflarni boshqarish samaradorligini oshirishga xizmat qiladi. Raqamlashtirish jarayonlari moliyaviy boshqaruv tizimiga yangi analitik instrumentlarni olib kirdi. Zamonaviy korxonalar faoliyatida Business Intelligence (BI) tizimlari, vizual monitoring platformalari va avtomatlashtirilgan tahlil vositalari keng qo‘llanilmoqda. Mazkur texnologiyalar real vaqt rejimida moliyaviy ko‘rsatkichlarni monitoring qilish, salbiy tendensiyalarni erta aniqlash hamda boshqaruv qarorlarini tezkor qabul qilish imkonini beradi. Ayniqsa, katta ma’lumotlar texnologiyalari va mashinali o‘rganish algoritmlaridan foydalanish moliyaviy tahlilning aniqligini oshirmoqda.

Shu sababli zamonaviy moliyaviy boshqaruv tizimida analitik instrumentlardan samarali foydalanish korxonaning raqobatbardoshligi va moliyaviy barqarorligini ta’minlovchi muhim omillardan biri hisoblanadi. Tadqiqot natijalari shuni ko‘rsatdiki, moliyaviy barqarorlikni boshqarish ko‘p qirrali va murakkab jarayon hisoblanadi. Korxonalarining moliyaviy holatini samarali boshqarish uchun klassik moliyaviy tahlil usullari bilan bir qatorda bankrotlikni prognozlash modellari, ekonometrik modellashtirish, stress-test mexanizmlari va biznes analitika tizimlaridan kompleks foydalanish zarur. Shuningdek, zamonaviy raqamli texnologiyalar va analitik instrumentlardan foydalanish moliyaviy risklarni erta aniqlash, boshqaruv qarorlarini asoslash hamda korxonalarining uzoq muddatli moliyaviy barqarorligini ta’minlash imkonini beradi.



“KELAJAK TEKNOLOGIYALARI VA SUN’IY INTELLEKT”
nomli respublika ilmiy-amaliy masofaviy konferensiyasi
VOLUME-1, ISSUE-2, 2026

Natijada moliyaviy barqarorlikni boshqarishda analitik instrumentlardan foydalanish korxonalarining iqtisodiy xavfsizligini mustahkamlash va ularning raqobatbardoshligini oshirishning muhim omili sifatida namoyon bo‘ladi.

FOYDALANGAN ADABIYOTLAR RO‘YXATI

1. Altman E.I. Financial Ratios, Discriminant Analysis and the Prediction of Corporate Bankruptcy // The Journal of Finance. – 1968. – Vol. 23. – No. 4. – pp. 589–609.
2. Brealey R.A., Myers S.C., Allen F. Principles of Corporate Finance. – New York: McGraw-Hill Education, 2022.
3. Савицкая Г.В. Анализ хозяйственной деятельности предприятия. – Минск: Новое знание, 2021.
4. Ковалев В.В. Финансовый анализ: методы и процедуры. – Москва: Финансы и статистика, 2020.
5. Шеремет А.Д. Теория экономического анализа. – Москва: ИНФРА-М, 2022.
6. Blank I.A. Financial Management. – Kyiv: Nika-Center, 2019.
7. Taffler R.J. Forecasting Company Failure in the UK Using Discriminant Analysis and Financial Ratio Data // Journal of the Royal Statistical Society. – 1983.



Current Issues of Personal Data Protection in the Digital Age

Aziza Donaeva

Senior Adviser at the Institute for Legislative Analysis and Regulatory Impact
Assessment under the Ministry of Justice

Annotation. This thesis analyzes the protection of personal data in the digital age as a modern legal and technological challenge. The rapid development of digital public services, financial technologies, e-commerce, social networks and artificial intelligence has significantly increased the volume of personal data being processed. As a result, the protection of privacy, information security and digital rights has become one of the most important issues for states and society. The thesis examines international statistics, foreign experience and possible directions for improving the legal framework of Uzbekistan.

Keywords: personal data, digital rights, information security, data breach, GDPR, privacy, cybersecurity.

“Raqamli davrda shaxsga doir ma’lumotlarni himoya qilishning dolzarb masalalari”

Aziza Donayeva,
Adliya vazirligi huzuridagi
Qonunchilikni tahlil qilish
va tartibga solish ta’sirini
baholash instituti katta maslahatchisi

Annotatsiya. Ushbu tezisdan raqamli davrda shaxsga doir ma’lumotlarni himoya qilish masalasi zamonaviy huquqiy va texnologik muammo sifatida tahlil qilinadi. Bugungi kunda davlat xizmatlari, bank-moliya tizimi, elektron tijorat, ijtimoiy tarmoqlar va sun’iy intellekt texnologiyalarining keng qo‘llanilishi natijasida shaxsiy ma’lumotlar hajmi keskin oshmoqda. Bu esa fuqarolarning shaxsiy hayoti daxlsizligi,



“KELAJAK TEKNOLOGIYALARI VA SUN’IY INTELLEKT”
nomli respublika ilmiy-amaliy masofaviy konferensiyasi
VOLUME-1, ISSUE-2, 2026

axborot xavfsizligi va raqamli huquqlarini ta’minlash zaruratini kuchaytirmoqda. Tezida xalqaro statistik ma’lumotlar, xorijiy tajriba hamda O‘zbekiston qonunchiligini takomillashtirish bo‘yicha takliflar yoritiladi.

Kalit so‘zlar: shaxsga doir ma’lumotlar, raqamli huquqlar, axborot xavfsizligi, data breach, GDPR, shaxsiy hayot daxlsizligi, kiberxavfsizlik.

Raqamli transformatsiya jarayoni inson hayotining deyarli barcha sohalariga kirib bordi. Bugungi kunda odamlar davlat xizmatlaridan foydalanish, bank amaliyotlarini bajarish, tovar va xizmatlarni xarid qilish, ijtimoiy tarmoqlarda muloqot qilish, ta’lim olish va tibbiy xizmatlardan foydalanish jarayonida doimiy ravishda shaxsga doir ma’lumotlarini taqdim etmoqda. Bunday ma’lumotlarga ism-sharif, tug‘ilgan sana, yashash manzili, telefon raqami, pasport ma’lumotlari, biometrik ma’lumotlar, bank kartasi rekvizitlari, geolokatsiya, tibbiy ma’lumotlar va boshqa shaxsni bevosita yoki bilvosita aniqlash imkonini beruvchi axborotlar kiradi.

Avvallari shaxsiy ma’lumotlar asosan qog‘oz hujjatlar yoki alohida idoraviy bazalarda saqlangan bo‘lsa, hozirgi davrda ular yirik raqamli platformalar, bulutli texnologiyalar, mobil ilovalar va sun’iy intellekt tizimlari orqali qayta ishlanmoqda. Shu sababli shaxsga doir ma’lumotlarni himoya qilish endilikda faqat texnik xavfsizlik masalasi emas, balki inson huquqlari, shaxsiy hayot daxlsizligi va davlatning raqamli boshqaruvdagi mas’uliyati bilan bog‘liq kompleks huquqiy masalaga aylandi.

Raqamli texnologiyalarning rivojlanishi bir tomondan inson hayotini yengillashtirayotgan bo‘lsa, ikkinchi tomondan shaxsiy ma’lumotlarning noqonuniy tarqalishi, sotilishi, firibgarlikda foydalanilishi yoki uchinchi shaxslarga ruxsatsiz uzatilishi xavfini oshirmoqda. Masalan, **2025-yil** boshida dunyo bo‘yicha internet foydalanuvchilari soni 5,56 milliard kishiga yetgan, bu esa yer aholisi umumiy sonining **67,9 foizini** tashkil etadi. Shu bilan birga, **2025-yilda** faol ijtimoiy tarmoq foydalanuvchi identifikatorlari soni **5,24 milliardga** yetgani qayd etilgan. Bu raqamlar shuni



“KELAJAK TEKNOLOGIYALARI VA SUN’IY INTELLEKT”
nomli respublika ilmiy-amaliy masofaviy konferensiyasi
VOLUME-1, ISSUE-2, 2026

ko‘rsatadiki, insonlarning shaxsiy ma‘lumotlari tobora ko‘proq raqamli muhitda shakllanmoqda va saqlanmoqda.

Shaxsga doir ma‘lumotlar buzilishi bilan bog‘liq holatlar ham yildan-yilga ortib bormoqda. Identity Theft Resource Center ma‘lumotlariga ko‘ra, **2024-yilda** AQSHda **3 158 ta** ma‘lumotlar buzilishi holati qayd etilgan va buning natijasida fuqarolarga **1,7 milliarddan** ortiq xabarnoma yuborilgan. Bu **2023-yilga** nisbatan jabrlanganlar haqidagi xabarnomalar soni **312 foizga** oshganini ko‘rsatadi. Mazkur holat shaxsiy ma‘lumotlar himoyasi nafaqat yirik texnologik kompaniyalar, balki davlat organlari, banklar, tibbiyot muassasalari va boshqa tashkilotlar uchun ham dolzarb muammo ekanini tasdiqlaydi.

Ma‘lumotlar buzilishining iqtisodiy oqibatlari ham juda katta. IBM‘ning **2025-yilgi “Cost of a Data Breach Report”** hisobotiga ko‘ra, dunyo bo‘yicha bitta ma‘lumotlar buzilishi holatining o‘rtacha qiymati **4,44 million** AQSH dollarini tashkil etgan. Bu xarajatlar faqat texnik tiklash ishlari bilan cheklanmaydi, balki sud xarajatlari, mijozlar ishonchini yo‘qotish, jarimalar, biznes obro‘sigacha yetgan zarar va xavfsizlik tizimlarini qayta qurish kabi omillarni ham o‘z ichiga oladi.

Shaxsga doir ma‘lumotlarning buzilishi fuqarolar uchun ham jiddiy oqibatlariga olib keladi. Masalan, pasport ma‘lumotlari yoki bank karta rekvizitlari sizib chiqsa, ular firibgarlik, kredit olish, soxta akkauntlar ochish yoki boshqa noqonuniy harakatlarda ishlatilishi mumkin. Telefon raqami, yashash manzili yoki geolokatsiya ma‘lumotlarining tarqalishi esa shaxsning xavfsizligi va shaxsiy hayoti daxlsizligiga bevosita tahdid tug‘diradi. Ayniqsa, tibbiy, biometrik va moliyaviy ma‘lumotlar eng nozik shaxsiy ma‘lumotlar hisoblanadi, chunki ular o‘zgartirib bo‘lmaydigan yoki uzoq muddatli oqibatlariga olib keladigan axborotlar sirasiga kiradi.

Xorijiy tajribaga nazar tashlaganda, Yevropa Ittifoqining Umumiy ma‘lumotlarni himoya qilish reglamenti — GDPR eng rivojlangan huquqiy mexanizmlardan biri



“KELAJAK TEKNOLOGIYALARI VA SUN’IY INTELLEKT”
nomli respublika ilmiy-amaliy masofaviy konferensiyasi
VOLUME-1, ISSUE-2, 2026

sifatida e’tirof etiladi. GDPR shaxsga doir ma’lumotlarni qayta ishlashda qonuniylik, adolatlilik, shaffoflik, maqsadga muvofiqlik, ma’lumotlarni minimallashtirish, aniqlik, saqlash muddatini cheklash va xavfsizlik prinsiplarini belgilaydi. Ushbu reglamentga ko‘ra, fuqaro o‘z ma’lumotlariga kirish, ularni tuzatish, o‘chirish, qayta ishlashni cheklash va ma’lumotlarni ko‘chirish huquqiga ega. Eng muhim jihatlardan biri shundaki, tashkilotlar shaxsiy ma’lumotlar bilan ishlashda fuqaroning aniq va ongli roziligini olishi, ma’lumotlar buzilishi yuz berganda esa vakolatli organga va ayrim hollarda fuqaroga xabar berishi shart.

Germaniya tajribasida shaxsiy ma’lumotlar himoyasi shaxsiy hayot daxlsizligi va inson qadr-qimmatini bilan uzviy bog‘liq holda qaraladi. Bu mamlakatda davlat organlari va xususiy sektor tomonidan ma’lumotlarni qayta ishlashda qat’iy nazorat mavjud. Har bir tashkilot ma’lumotlarni yig‘ishdan oldin uning aniq maqsadini belgilashi, ortiqcha ma’lumotlarni talab qilmasligi va fuqaro roziligini asosli shaklda olishi lozim. Bunday yondashuv shaxsiy ma’lumotlarni “cheksiz resurs” sifatida emas, balki inson huquqlariga bevosita taalluqli himoyalangan axborot sifatida ko‘rishga asoslanadi.

Estoniya tajribasi ham raqamli davlat boshqaruvi sharoitida shaxsiy ma’lumotlarni himoya qilish bo‘yicha muhim ahamiyatga ega. Estoniyada elektron hukumat, elektron identifikatsiya va raqamli imzo tizimlari keng rivojlangan. Shu bilan birga, fuqaro o‘z ma’lumotlariga qaysi davlat organi yoki tashkilot kirganini ko‘rish imkoniyatiga ega. Bu ochiqlik mexanizmi davlat organlarining mas’uliyatini oshiradi va fuqarolarda raqamli xizmatlarga nisbatan ishonchni mustahkamlaydi. Demak, raqamli davlat qurishda faqat xizmatlarni elektronlashtirish yetarli emas, balki fuqaroga o‘z ma’lumotlari ustidan nazorat qilish imkoniyatini ham berish zarur.

Janubiy Koreya tajribasida esa ma’lumotlar sizib chiqishi uchun javobgarlik mexanizmlari kuchli yo‘lga qo‘yilgan. Mazkur davlatda shaxsiy ma’lumotlarni himoya qilish bo‘yicha alohida nazorat organlari faoliyat yuritadi, tashkilotlarga ma’lumotlar



“KELAJAK TEKNOLOGIYALARI VA SUN’IY INTELLEKT”
nomli respublika ilmiy-amaliy masofaviy konferensiyasi
VOLUME-1, ISSUE-2, 2026

xavfsizligini ta’minlash bo’yicha aniq majburiyatlar yuklatiladi. Shuningdek, ma’lumotlar buzilishi holatlarida jarimalar va kompensatsiya mexanizmlari qo’llaniladi. Bu tajriba shuni ko’rsatadiki, shaxsiy ma’lumotlarni himoya qilishda faqat deklarativ normalar emas, balki real javobgarlik va nazorat mexanizmlari muhim o‘rin tutadi.

O‘zbekiston Respublikasida ham shaxsga doir ma’lumotlarni himoya qilish bo’yicha muayyan huquqiy asoslar shakllangan. “Shaxsga doir ma’lumotlar to‘g‘risida”gi Qonun shaxsga doir ma’lumotlarni yig‘ish, tizimlashtirish, saqlash, o‘zgartirish, foydalanish, berish, tarqatish va yo‘q qilish bilan bog‘liq munosabatlarni tartibga soladi. Ushbu qonunda shaxsga doir ma’lumotlar subyekti, operator, ma’lumotlarni qayta ishlash, rozilik, maxsus shaxsiy ma’lumotlar kabi asosiy tushunchalar belgilangan. Biroq raqamli texnologiyalar tez rivojlanayotgani sababli amaldagi qonunchilikni zamonaviy xavflarga mos ravishda doimiy takomillashtirib borish zarur.

Xususan, bugungi kunda O‘zbekistonda elektron davlat xizmatlari, bank ilovalari, onlayn savdo platformalari, ta’lim platformalari va turli mobil ilovalar orqali katta hajmdagi shaxsiy ma’lumotlar qayta ishlanmoqda. Aholi ko‘pincha ilovalardan foydalanishda maxfiylik siyosatini o‘qimasdan rozilik beradi. Ayrim hollarda esa tashkilotlar foydalanuvchidan xizmat ko‘rsatish uchun zarur bo‘lmagan ortiqcha ma’lumotlarni ham talab qiladi. Bu esa “ma’lumotlarni minimallashtirish” prinsipini milliy qonunchilik va amaliyotda kuchaytirish zarurligini ko‘rsatadi.

Shaxsiy ma’lumotlarni himoya qilishda eng muhim masalalardan biri fuqarolarning xabardorlik darajasidir. Ko‘pchilik foydalanuvchilar o‘z ma’lumotlarining qanday qayta ishlanishi, kimlarga uzatilishi yoki qanday muddat saqlanishi haqida yetarli ma’lumotga ega emas. Shu sababli davlat organlari va xususiy tashkilotlar tomonidan maxfiylik siyosati sodda, tushunarli va foydalanuvchiga qulay shaklda taqdim etilishi kerak. Fuqaro roziligi esa avtomatik belgilangan katakcha yoki



“KELAJAK TEKNOLOGIYALARI VA SUN’IY INTELLEKT”
nomli respublika ilmiy-amaliy masofaviy konferensiyasi
VOLUME-1, ISSUE-2, 2026

umumiy ibora orqali emas, balki aniq, ongli va erkin bildirilgan rozilik sifatida rasmiylashtirilishi lozim.

Yana bir dolzarb masala — ma’lumotlar buzilishi yuz berganda xabar berish majburiyatini kuchaytirishdir. Xorijiy tajribada, ayniqsa GDPR doirasida, tashkilotlar ma’lumotlar buzilishi haqida belgilangan muddatda nazorat organiga xabar berishi kerak. Agar buzilish fuqarolarning huquq va erkinliklariga jiddiy xavf tug‘dirsa, bu haqda ma’lumot subyektlariga ham xabar beriladi. O‘zbekiston amaliyotida ham bunday mexanizmni yanada aniq belgilash, ya’ni qaysi holatda, qancha muddatda va qanday tartibda xabar berilishi kerakligini qonunchilikda mustahkamlash maqsadga muvofiq.

Sun’iy intellekt texnologiyalarining rivojlanishi shaxsga doir ma’lumotlar himoyasi uchun yangi muammolarni yuzaga keltirmoqda. AI tizimlari katta hajmdagi ma’lumotlar asosida ishlaydi va ayrim hollarda foydalanuvchining xatti-harakati, qiziqishlari, xarid odatlari, siyosiy yoki ijtimoiy qarashlari haqida taxminiy profil yaratishi mumkin. Agar bunday tizimlar ustidan yetarli nazorat bo‘lmasa, shaxsiy ma’lumotlar diskriminatsiya, manipulyatsiya yoki nohaq qarorlar qabul qilishda ishlatilishi mumkin. Shu bois algoritmik shaffoflik, avtomatlashtirilgan qarorlar ustidan inson nazorati va AI tizimlarida shaxsiy ma’lumotlardan foydalanish chegaralarini belgilash muhim ahamiyatga ega.

O‘zbekiston uchun ushbu sohada bir nechta muhim yo‘nalishlarni belgilash mumkin. Avvalo, shaxsga doir ma’lumotlarni qayta ishlashda “zarur minimum” prinsipini kuchaytirish kerak. Ya’ni tashkilotlar faqat xizmat ko‘rsatish uchun zarur bo‘lgan ma’lumotlarni so‘rashi va ortiqcha ma’lumotlarni yig‘masligi lozim. Ikkinchidan, ma’lumotlar buzilishi haqida majburiy xabar berish tartibini aniq belgilash zarur. Uchinchidan, fuqarolarga o‘z ma’lumotlariga kim kirgani, ular qanday maqsadda ishlatilgani va qaysi muddat saqlanishi haqida ma’lumot olish imkoniyati kengaytirilishi kerak. To‘rtinchidan, davlat organlari va xususiy sektor uchun muntazam kiberxavfsizlik



“KELAJAK TEKNOLOGIYALARI VA SUN’IY INTELLEKT”
nomli respublika ilmiy-amaliy masofaviy konferensiyasi
VOLUME-1, ISSUE-2, 2026

auditi va shaxsiy ma’lumotlar himoyasi bo‘yicha ichki nazorat mexanizmlarini joriy etish maqsadga muvofiq.

Bundan tashqari, shaxsiy ma’lumotlarni himoya qilish bo‘yicha aholining huquqiy madaniyatini oshirish zarur. Maktab, oliy ta’lim muassasalari va ommaviy axborot vositalari orqali raqamli gigiyena, parol xavfsizligi, ikki bosqichli autentifikatsiya, shubhali havolalardan ehtiyot bo‘lish, shaxsiy hujjatlarni internetda tarqatmaslik kabi oddiy, ammo muhim qoidalar tushuntirilishi kerak. Chunki hatto eng kuchli qonunchilik ham foydalanuvchi o‘z ma’lumotlarini ehtiyotsizlik bilan tarqatsa, to‘liq samara bermaydi.

Xulosa qilib aytganda, raqamli davrda shaxsga doir ma’lumotlarni himoya qilish davlat, biznes va fuqarolar o‘rtasidagi ishonchning muhim shartidir. Internet foydalanuvchilari sonining milliardlab kishiga yetgani, data breach holatlarining keskin oshgani va bitta ma’lumotlar buzilishining o‘rtacha qiymati millionlab dollarni tashkil etayotgani ushbu masalaning global ahamiyatini ko‘rsatadi. O‘zbekiston raqamli transformatsiya jarayonida shaxsiy ma’lumotlar himoyasini nafaqat texnik xavfsizlik, balki inson huquqlarini himoya qilishning muhim elementi sifatida ko‘rishi zarur. Shu ma’noda xalqaro tajribani o‘rganish, milliy qonunchilikni takomillashtirish, fuqarolarning raqamli huquqlarini kengaytirish va tashkilotlarning javobgarligini kuchaytirish kelgusida shaxsiy ma’lumotlar xavfsizligini ta’minlashning asosiy omillaridan biri bo‘lib xizmat qiladi.



“KELAJAK TEKNOLOGIYALARI VA SUN’IY INTELLEKT”
nomli respublika ilmiy-amaliy masofaviy konferensiyasi
VOLUME-1, ISSUE-2, 2026

ADAPTIVE LEARNING SYSTEMS IN TEACHING THE ENGLISH LANGUAGE

Shavkat Mamirovich Ibragimov

Fergana State University, Associate Professor of the Department of Information
Technologies

shavkat70@bk.ru +998 90 530 18 04 <http://orcid.org/0000-0001-7812-1898>

Nozanin Otabekovna Ma’murova

mamurovanancy1024@gmail.com

Fergana State University Student of the program “Philology and Language Teaching”
(English Language)

Abstract: The article examines adaptive learning systems as a tool for personalizing the process of teaching the English language in the context of the digitalization of higher education. The purpose of the study is to investigate adaptive technologies and assess their impact on the effectiveness of language learning. The working hypothesis proposes that the systematic adaptation of the educational process according to the level of task complexity, learning pace, format of material presentation, and nature of feedback ensures a statistically significant improvement in English language learning outcomes. To test the hypothesis, a twelve-week pedagogical experiment was conducted involving ninety-six first-year students. The results indicate a significant advantage of the experimental group in terms of active vocabulary volume, accuracy of grammatical constructions, and level of listening competence. The scientific novelty of the work lies in the systematization of adaptation parameters in relation to teaching the English language and in the substantiation of an integrative model combining adaptive platforms with classroom forms of instruction. The practical value is expressed in the formulation of recommendations for teachers on the selection and application of adaptive platforms.



“KELAJAK TEKNOLOGIYALARI VA SUN’IY INTELLEKT”
nomli respublika ilmiy-amaliy masofaviy konferensiyasi
VOLUME-1, ISSUE-2, 2026

Keywords: adaptive learning systems, teaching the English language, personalized learning, intelligent tutoring systems, artificial intelligence in education, digital didactics, educational technologies.

ВВЕДЕНИЕ

Стремительное развитие цифровых технологий и искусственного интеллекта на протяжении последних двух десятилетий принципиально изменило ландшафт лингвистического образования. Традиционная фронтальная модель преподавания иностранного языка, рассчитанная на условно «среднего» учащегося, всё чаще обнаруживает свою ограниченность в условиях разнородных групп с различным исходным уровнем владения языком, разной мотивацией и несхожими стилями восприятия материала. В этих условиях адаптивные обучающие системы, способные подстраивать содержание, последовательность и темп обучения под индивидуальные характеристики учащегося, выступают одним из наиболее перспективных средств повышения эффективности преподавания английского языка.

Актуальность исследования определяется тремя факторами. Во-первых, экспоненциальный рост числа онлайн-платформ для изучения английского языка (Duolingo, Babbel, Busuu, Memrise, Rosetta Stone) сделал адаптивные технологии массово доступным образовательным инструментом. Во-вторых, переход высших учебных заведений Республики Узбекистан и многих других стран к смешанному формату обучения создал потребность в инструментах, обеспечивающих преемственность аудиторной и самостоятельной работы. В-третьих, развитие генеративного искусственного интеллекта существенно расширило возможности адаптивных систем: они получили способность не только выбирать готовые задания, но и генерировать индивидуализированные тексты, диалоги и упражнения в режиме реального времени.



“KELAJAK TEKNOLOGIYALARI VA SUN’IY INTELLEKT”
nomli respublika ilmiy-amaliy masofaviy konferensiyasi
VOLUME-1, ISSUE-2, 2026

Цель исследования - изучить адаптивные технологии в преподавании английского языка и оценить их влияние на результативность учебного процесса. Гипотеза работы заключается в следующем: применение адаптивных обучающих систем приводит к статистически значимому повышению результатов обучения английскому языку по сравнению с традиционной неадаптивной методикой. Научная новизна исследования состоит в систематизации параметров адаптации применительно к преподаванию английского языка и в обосновании интегративной модели сочетания адаптивных систем с аудиторными формами работы. Практическая ценность работы выражается в разработке рекомендаций для преподавателей вузов и языковых курсов по выбору адаптивных платформ и проектированию учебных заданий с учётом возможностей таких систем.

ОБЗОР ЛИТЕРАТУРЫ

Концепция адаптивного обучения уходит корнями в работы Л. С. Выготского, обосновавшего понятие зоны ближайшего развития, и Б. Блума, эмпирически продемонстрировавшего эффективность индивидуального тьютора в рамках известного «феномена двух сигм». Современный этап развития адаптивных обучающих систем связан с появлением интеллектуальных обучающих систем, фундаментальные принципы построения которых сформулированы в работах Дж. Андерсона и А. Корбетта (алгоритм байесовского отслеживания знаний) и К. ВанЛена (сравнительный мета-анализ их эффективности). Вопросы адаптации в гипермедийной среде подробно исследованы П. Брусиловским, выделившим адаптивную презентацию материала, адаптивную навигацию и адаптивный отбор содержания. Среди отечественных исследователей значительный вклад в разработку теории внесли Л. А. Растринин, А. В. Соловов и А. И. Башмаков.



“KELAJAK TEKNOLOGIYALARI VA SUN’IY INTELLEKT”
nomli respublika ilmiy-amaliy masofaviy konferensiyasi
VOLUME-1, ISSUE-2, 2026

В области преподавания английского языка применение адаптивных технологий исследовано в работах С. Торнбьюри, П. Уру и других специалистов. Особое внимание уделено адаптации уровня сложности по шкале CEFR, индивидуализации работы с лексикой и персонализации устной практики на основе технологий распознавания речи. Эмпирические исследования эффективности популярных платформ, в частности Duolingo (Vesselinov & Grego, 2012; Nielson, 2011), демонстрируют положительные результаты в формировании рецептивных навыков, однако указывают на ограничения в развитии продуктивных коммуникативных умений. Несмотря на значительный объём литературы, вопросы интеграции адаптивных систем в учебный процесс высшей школы и количественной оценки их эффекта в условиях многоязычной образовательной среды остаются недостаточно разработанными.

МЕТОДОЛОГИЯ

Для проверки выдвинутой гипотезы было организовано исследование, сочетающее теоретический анализ источников и педагогический эксперимент. Теоретический этап включал систематический обзор работ по адаптивным обучающим системам, опубликованных в период с 2000 по 2025 год, а также анализ функциональных возможностей восьми адаптивных платформ для изучения английского языка. На основании анализа выделены четыре ключевых параметра адаптации: уровень сложности заданий, темп прохождения материала, формат подачи (текст, аудио, видео, диалог) и характер обратной связи.

Эмпирический этап реализован в форме педагогического эксперимента продолжительностью двенадцать недель с участием девяноста шести студентов первого курса неязыковых направлений, разделённых на экспериментальную ($n = 48$) и контрольную ($n = 48$) группы. Группы были выровнены по входному уровню владения языком (A2 по шкале CEFR). В контрольной группе занятия



“KELAJAK TEKNOLOGIYALARI VA SUN’IY INTELLEKT”
nomli respublika ilmiy-amaliy masofaviy konferensiyasi
VOLUME-1, ISSUE-2, 2026

проводились по традиционной коммуникативной методике; в экспериментальной - аудиторные занятия дополнялись систематической работой с адаптивной платформой не менее тридцати минут ежедневно с автоматической подстройкой содержания самостоятельной работы под индивидуальные результаты.

В качестве показателей результативности использовались: объём активного словарного запаса (по результатам тестирования с заданиями продуктивного типа), точность употребления грамматических структур (по результатам письменной работы) и уровень аудитивной компетенции (по итогам стандартизированного теста). Дополнительно фиксировался показатель учебной вовлечённости. Статистическая значимость различий оценивалась с использованием t-критерия Стьюдента при уровне значимости $\alpha = 0,05$.

РЕЗУЛЬТАТЫ

Сопоставительный анализ функциональных возможностей восьми адаптивных платформ позволил выявить существенные различия в реализации параметров адаптации, обобщённые в таблице 1. Платформы Duolingo и Busuu обнаруживают наибольшую гибкость в одновременной адаптации уровня сложности и темпа прохождения, тогда как Rosetta Stone и ELSA Speak делают акцент на адаптации фонетической составляющей через продвинутые системы распознавания речи.

Сравнительный анализ адаптивных платформ для изучения английского языка.

Таблица 1.

Платформа	Адаптация сложности	Адаптация темпа	Распознавание речи	Генеративный ИИ
Duolingo	Высокая	Высокая	Средняя	Внедрён



“KELAJAK TEKNOLOGIYALARI VA SUN’IY INTELLEKT”
nomli respublika ilmiy-amaliy masofaviy konferensiyasi
VOLUME-1, ISSUE-2, 2026

Платформа	Адаптация сложности	Адаптация темпа	Распознавание речи	Генеративный ИИ
Busuu	Высокая	Высокая	Высокая	Внедрён
Babbel	Средняя	Средняя	Средняя	Частично
Rosetta Stone	Средняя	Средняя	Высокая	Отсутствует
Memrise	Высокая	Высокая	Средняя	Частично
Lingoda AI	Высокая	Средняя	Высокая	Внедрён
ELSA Speak	Средняя	Высокая	Очень высокая	Внедрён
Speakly	Высокая	Высокая	Высокая	Частично

По итогам педагогического эксперимента зафиксирован статистически значимый прирост результатов в экспериментальной группе по всем трём измеряемым параметрам (таблица 2). Объём активного словарного запаса увеличился в среднем на 38,2%, тогда как в контрольной группе прирост составил 21,4%. Точность употребления грамматических структур повысилась на 24,7% против 14,3% соответственно. Уровень аудитивной компетенции возрос на 31,5% против 18,9%. Полученные значения t-критерия превысили критическое значение во всех трёх случаях ($p < 0,05$), что подтверждает статистическую значимость различий и, следовательно, выдвинутую гипотезу.

Динамика показателей контрольной (КГ) и экспериментальной (ЭГ) групп.

Таблица 2.



“KELAJAK TEKNOLOGIYALARI VA SUN’IY INTELLEKT”
nomli respublika ilmiy-amaliy masofaviy konferensiyasi
VOLUME-1, ISSUE-2, 2026

Показатель	КГ до	КГ после	ЭГ до	ЭГ после
Активный словарный запас (ед.)	847	1028 (+21,4%)	852	1178 (+38,2%)
Точность грамматики (%)	58,3	66,7 (+14,3%)	57,9	72,2 (+24,7%)
Аудитивная компетенция (балл)	12,7	15,1 (+18,9%)	12,9	16,9 (+31,5%)
Вовлечённость (по опросу, балл из 10)	6,2	6,8	6,1	8,4

Качественный анализ обратной связи студентов экспериментальной группы выявил три значимые тенденции. Во-первых, обучающиеся отмечали более высокую вовлечённость и устойчивость учебной мотивации, связывая это с возможностью видеть прогресс в реальном времени и с переживанием посильной сложности заданий. Во-вторых, наибольший относительный прирост зафиксирован у студентов, изначально находившихся ниже среднего уровня группы, что согласуется с теоретическим положением о компенсаторной функции адаптивных систем. В-третьих, использование платформ с генеративными возможностями обеспечило значимое преимущество в развитии продуктивных навыков.

ВЫВОДЫ

Проведённое исследование подтверждает гипотезу о повышении результативности обучения английскому языку при систематическом применении адаптивных обучающих систем. Адаптация по четырём ключевым параметрам -



“KELAJAK TEKNOLOGIYALARI VA SUN'IY INTELLEKT”
nomli respublika ilmiy-amaliy masofaviy konferensiyasi
VOLUME-1, ISSUE-2, 2026

уровню сложности, темпу, формату и характеру обратной связи - позволяет достичь статистически значимого преимущества в формировании лексической, грамматической и аудитивной компетенций. Наибольший эффект наблюдается у обучающихся с относительно низким исходным уровнем владения языком, что свидетельствует о выравнивающем потенциале адаптивных систем.

Научная новизна работы состоит в систематизации параметров адаптации применительно к преподаванию английского языка и в эмпирическом обосновании комплексной модели интеграции адаптивных систем в учебный процесс высшей школы. Практическая ценность исследования выражается в сформулированных рекомендациях: преподавателям рекомендуется использовать адаптивные системы как дополнение к аудиторной коммуникативной практике, выбирая платформы, обеспечивающие адаптацию по нескольким параметрам одновременно. Перспективы дальнейшего исследования связаны с изучением долгосрочного эффекта применения адаптивных обучающих систем и разработкой методических моделей интеграции генеративного искусственного интеллекта в курсы английского языка.

Список литературы

1. Башмаков А. И., Башмаков И. А. Разработка компьютерных учебников и обучающих систем. - М.: Информационно-издательский дом «Филинь», 2003. - 616 с.
2. Выготский Л. С. Педагогическая психология / Под ред. В. В. Давыдова. - М.: Педагогика-Пресс, 1996. - 536 с.
3. Растрин Л. А. Адаптация сложных систем. - Рига: Зинатне, 1981. - 375 с.
4. Соловов А. В. Электронное обучение: проблематика, дидактика, технология. - Самара: Новая техника, 2006. - 462 с.



“KELAJAK TEKNOLOGIYALARI VA SUN’IY INTELLEKT”
nomli respublika ilmiy-amaliy masofaviy konferensiyasi
VOLUME-1, ISSUE-2, 2026

5. Anderson J. R., Corbett A. T., Koedinger K. R., Pelletier R. Cognitive Tutors: Lessons Learned // Journal of the Learning Sciences. - 1995. - Vol. 4, No. 2. - P. 167–207.
6. Bloom B. S. The 2 Sigma Problem: The Search for Methods of Group Instruction as Effective as One-to-One Tutoring // Educational Researcher. - 1984. - Vol. 13, No. 6. - P. 4–16.
7. Brusilovsky P. Adaptive Hypermedia // User Modeling and User-Adapted Interaction. - 2001. - Vol. 11, No. 1–2. - P. 87–110.
8. Corbett A. T., Anderson J. R. Knowledge Tracing: Modeling the Acquisition of Procedural Knowledge // User Modeling and User-Adapted Interaction. - 1995. - Vol. 4. - P. 253–278.
9. Kulik J. A., Fletcher J. D. Effectiveness of Intelligent Tutoring Systems: A Meta-Analytic Review // Review of Educational Research. - 2016. - Vol. 86, No. 1. - P. 42–78.
10. Nielson K. B. Self-study with Language Learning Software in the Workplace // Language Learning & Technology. - 2011. - Vol. 15, No. 3. - P. 110–129.
11. Pavlik P. I., Anderson J. R. Using a Model to Compute the Optimal Schedule of Practice // Journal of Experimental Psychology: Applied. - 2008. - Vol. 14, No. 2. - P. 101–117.
12. VanLehn K. The Relative Effectiveness of Human Tutoring, Intelligent Tutoring Systems, and Other Tutoring Systems // Educational Psychologist. - 2011. - Vol. 46, No. 4. - P. 197–221.
13. Vesselinov R., Grego J. Duolingo Effectiveness Study: Final Report. - New York: City University of New York, 2012. - 25 p.



**THE IMPACT OF FUTURE TECHNOLOGIES AND ARTIFICIAL
INTELLIGENCE ON THE GLOBAL ECONOMY**

Norqulova Sevinch Asliddin qizi

Tashkent State University of Economics Faculty of Economics

sevinchnorqulova29@gmail.com

Abstract

The accelerated development of future technologies and artificial intelligence (AI) profoundly impacts the global economic system, revolutionizing the functioning of corporations, governmental agencies, as well as private citizens' life and work. Technologies like machine learning, robotics, blockchain, cloud computing, biotechnology, quantum computing, and the Internet of Things (IoT) have become indispensable aspects of economic growth in both developed and underdeveloped countries. Technological innovations allow for raising productivity levels, promoting innovations, decreasing expenses and helping businesses to better compete in the international business environment. Artificial intelligence is an integral part of the contemporary technological landscape. The capabilities of intelligent machines and software systems include the analysis of vast amounts of data, identification of patterns, prediction of outcomes and performance of actions which usually can only be performed by human intelligence. Corporations widely employ AI to automate production processes, provide clients with adequate services, streamline logistics and make strategic decisions. Governmental agencies also utilize smart technologies in the spheres of health care, education, transportation and public management.

Key words

Artificial Intelligence, Future Technologies, Digital Economy, Innovation, Automation, Machine Learning, Robotics, Economic Growth, Industry 4.0, Globalization, Smart Technologies, Employment.



“KELAJAK TEKNOLOGIYALARI VA SUN’IY INTELLEKT”
nomli respublika ilmiy-amaliy masofaviy konferensiyasi
VOLUME-1, ISSUE-2, 2026

Indeed, technology is one of the leading forces that drive the economy and social development. Over time, humankind has gone through a number of technological revolutions that have significantly affected the transformation of production, transportation, communications, and trade. The first revolution was associated with mechanized manufacturing in the course of the industrial revolution. The second one brought computers and the Internet during the information revolution. Currently, the world faces yet another phase of technological development that has come to be known as the Fourth Industrial Revolution, which involves the development of artificial intelligence, automation, robotics, and digital technology.

The concept of artificial intelligence involves the capacity of computing machines to simulate human intelligence and implement such functions as reasoning, learning, problem-solving, and decision-making. Different from traditional computer programming, AI technologies allow for gradual improvement based on experience and data analysis. One of the areas within the field of artificial intelligence is machine learning that enables computers to recognize patterns and predict outcomes without specific programming.

Undoubtedly, future technologies are having a profound impact on every sphere of the global economy. Within the medical industry, artificial intelligence technologies help physicians diagnose patients faster and more effectively. The economic importance of artificial intelligence is increasing every year. Major technology companies and governments invest billions of dollars in AI research and infrastructure. Countries that successfully develop and implement AI technologies are expected to gain competitive advantages in global trade and innovation. As a result, technological leadership has become an important element of international economic power.

The purpose of this thesis is to analyze the relationship between future technologies, artificial intelligence, and the global economy. The study explores the



“KELAJAK TEKNOLOGIYALARI VA SUN’IY INTELLEKT”
nomli respublika ilmiy-amaliy masofaviy konferensiyasi
VOLUME-1, ISSUE-2, 2026

economic benefits of technological innovation, its influence on employment and business, and the risks associated with digital transformation. Additionally, the thesis discusses possible future developments and strategies for creating a balanced and sustainable digital economy.

Future technologies refer to advanced scientific and technological innovations that are expected to play a major role in shaping society and the economy in the coming decades. These technologies are transforming industries, improving communication, and increasing efficiency across different sectors.

Some of the most important future technologies include:

- Artificial Intelligence (AI)
- Machine Learning
- Robotics
- Blockchain Technology
- Quantum Computing
- Internet of Things (IoT)
- 5G Networks
- Cloud Computing
- Biotechnology
- Nanotechnology

These technologies are interconnected and often work together to create intelligent systems. For example, IoT devices collect large amounts of data, cloud computing stores and processes this information, and AI systems analyze it to make decisions.

One of the most influential technologies is artificial intelligence. AI systems can perform tasks that normally require human intelligence, such as image recognition, language translation, and strategic planning. Machine learning enables systems to improve their performance through data analysis and experience. Deep learning, a more



“KELAJAK TEKNOLOGIYALARI VA SUN’IY INTELLEKT”
nomli respublika ilmiy-amaliy masofaviy konferensiyasi
VOLUME-1, ISSUE-2, 2026

advanced branch of machine learning, uses neural networks inspired by the human brain to solve complex problems.

Robotics is another rapidly growing field. Modern robots are capable of performing industrial, medical, and household tasks with high precision. In manufacturing, robots increase productivity and reduce human error. In medicine, robotic surgery improves the accuracy of operations and reduces recovery time for patients.

Blockchain technology has revolutionized digital transactions and financial systems. Blockchain creates decentralized and secure digital records that cannot easily be modified. Cryptocurrencies such as Bitcoin are based on blockchain technology, but blockchain also has applications in supply chain management, healthcare, and digital identity verification.

Quantum computing represents one of the most advanced technological developments. Unlike traditional computers that use binary systems, quantum computers use quantum bits or qubits, enabling them to solve extremely complex calculations much faster than conventional systems. Although quantum computing is still developing, it may revolutionize scientific research, medicine, and cybersecurity in the future.

In the current economy, artificial intelligence is seen as one of the leading factors driving economic growth. AI solutions increase the pace and efficiency of operations, help optimize the usage of resources, and provide new opportunities for innovation and entrepreneurial activities.

Economic growth refers to an increase in the production of goods and services. Artificial intelligence is used to automate repetitive tasks, improve efficiency, and minimize operational costs, which, in turn, makes it possible for businesses to increase their output significantly.

In manufacturing industries, for instance, robots are programmed to carry out assembly operations continuously without getting tired or taking breaks. Besides, the smart factory



“KELAJAK TEKNOLOGIYALARI VA SUN’IY INTELLEKT”
nomli respublika ilmiy-amaliy masofaviy konferensiyasi
VOLUME-1, ISSUE-2, 2026

uses sensors and other intelligent solutions to monitor the performance of machinery and optimize production.

Another aspect where AI improves business is decision-making. Modern enterprises collect information about customers and market trends. Then, using algorithms and analytics software, companies predict consumer demands and behavior and offer personalized solutions that maximize sales.

Artificial intelligence will continue to transform industries such as healthcare, education, agriculture, and manufacturing. Personalized medicine, online learning platforms, and smart farming systems will improve quality of life and resource management.

The future economy will likely depend heavily on innovation, creativity, and technological knowledge. Countries that invest in education, research, and digital infrastructure will gain competitive advantages in global markets.

International competition for technological leadership is intensifying. The United States, China, Japan, South Korea, and European countries invest heavily in AI research and semiconductor production. Technological leadership increasingly influences geopolitical power and economic stability.

However, international cooperation continues to play an important role. Challenges such as climate change, pandemics, and cyber security issues need technological cooperation on a global scale.

According to specialists, in the future, the cooperation between people and advanced intelligent systems will continue instead of replacing humans by robots. The collaboration will help people solve problems, become more productive, and generate new ideas.

Also, the digital economy provides new possibilities for less-developed countries. These nations can get access to remote learning, digital banking, and trading via e-commerce



“KELAJAK TEKNOLOGIYALARI VA SUN’IY INTELLEKT”
nomli respublika ilmiy-amaliy masofaviy konferensiyasi
VOLUME-1, ISSUE-2, 2026

platforms. Yet, investment in infrastructure and education is required to minimize the digital gap between developed and less developed nations.

In conclusion, the future of the global economy depends on finding the right balance between innovation and social responsibility. The rapid development of artificial intelligence systems has significantly changed the structure of the world economy. In addition, AI technologies increase productivity, stimulate innovation and boost effectiveness in such sectors as medicine, financial services, education, transport, and production. The implementation of intelligent systems allows organizations and governments to optimize their activities, minimize expenses, and enhance their decision-making processes.

The economic advantages of using intelligent technologies are considerable. Automation increases the efficiency and accuracy of production,

References

1. Brynjolfsson, E., & McAfee, A. *The Second Machine Age*. W.W. Norton & Company, 2014.
2. Russell, S., & Norvig, P. *Artificial Intelligence: A Modern Approach*. Pearson Education, 2021.
3. Schwab, K. *The Fourth Industrial Revolution*. World Economic Forum, 2016.
4. Ford, M. *Rise of the Robots: Technology and the Threat of a Jobless Future*. Basic Books, 2015.
5. OECD. *Artificial Intelligence in Society*. OECD Publishing, 2019.
6. World Economic Forum. *The Future of Jobs Report*. 2023.
7. Kaplan, J. *Artificial Intelligence: What Everyone Needs to Know*. Oxford University Press, 2016.
8. Bessen, J. *AI and Jobs: The Role of Demand*. NBER Working Paper, 2019.



“KELAJAK TEKNOLOGIYALARI VA SUN’IY INTELLEKT”
nomli respublika ilmiy-amaliy masofaviy konferensiyasi
VOLUME-1, ISSUE-2, 2026

9. United Nations Conference on Trade and Development (UNCTAD). *Digital Economy Report*. 2021.
10. McKinsey Global Institute. *The Age of AI: Artificial Intelligence and the Future of Work*. 2022.
11. Harari, Y. N. *Homo Deus: A Brief History of Tomorrow*. Harper, 2017.
12. Tegmark, M. *Life 3.0: Being Human in the Age of Artificial Intelligence*. Knopf, 2017.
13. European Commission. *Artificial Intelligence for Europe*. Brussels, 2020.
14. IBM Research. *The Future of Artificial Intelligence and Business*. 2021.
15. PwC Global. *Sizing the Prize: What’s the Real Value of AI for Your Business and How Can You Capitalize?* 2022.



METHODS OF MANAGING AND EVALUATING INVESTMENT PROCESSES

Xolniovov Asrorjon

2nd-year Master’s Student, Economics Program Termiz University of Economics
and Service

E-mail: asrorjonxolniovov@gmail.com

Abstract. This article discusses the theoretical foundations of managing and evaluating investment processes. The mechanisms for effectively organizing investment activities, managing investment projects, and determining their economic efficiency are analyzed. In addition, the study examines the main indicators used in evaluating investment projects, modern management methods, and ways to improve investment efficiency. As a result of the research, conclusions and recommendations were developed for improving investment processes and increasing investment activity.

Keywords: investment, investment process, investment project, investment management, investment evaluation, economic efficiency, investment activity, net present value, profitability, investment environment

INVESTITSIYA JARAYONLARINI BOSHQARISH VA BAHOLASH USULLARI

Xolniovov Asrorjon

Termiz iqtisodiyot va servis universiteti Magistratura 2-kurs Iqtisodiyot yo’nalishi

asrorjonxolniovov@gmail.com

Annotatsiya. Mazkur maqolada investitsiya jarayonlarini boshqarish va baholashning nazariy asoslari yoritilgan. Investitsiya faoliyatini samarali tashkil etish, investitsiya loyihalarini boshqarish mexanizmlari hamda ularning iqtisodiy samaradorligini aniqlash usullari tahlil qilingan. Shuningdek, investitsiya loyihalarini



“KELAJAK TEKNOLOGIYALARI VA SUN’IY INTELLEKT”
nomli respublika ilmiy-amaliy masofaviy konferensiyasi
VOLUME-1, ISSUE-2, 2026

baholashda qo‘llaniladigan asosiy ko‘rsatkichlar, zamonaviy boshqaruv usullari va investitsiya samaradorligini oshirish yo‘llari ko‘rib chiqilgan. Tadqiqot natijasida investitsiya jarayonlarini takomillashtirish va investitsion faollikni oshirish bo‘yicha xulosa hamda tavsiyalar ishlab chiqilgan.

Kalit so‘zlar: investitsiya, investitsiya jarayoni, investitsiya loyihasi, investitsiyalarni boshqarish, investitsiyani baholash, iqtisodiy samaradorlik, investitsion faoliyat, sof joriy qiymat, rentabellik, investitsiya muhiti.

Kirish:

Hozirgi kunda investitsiyalar iqtisodiyotni rivojlantirish, ishlab chiqarishni kengaytirish va innovatsion texnologiyalarni joriy etishda muhim ahamiyat kasb etmoqda. Investitsiya faoliyatining samaradorligi esa investitsiya jarayonlarini to‘g‘ri boshqarish va baholash bilan chambarchas bog‘liqdir. Shu sababli investitsiya jarayonlarini boshqarish mexanizmlarini takomillashtirish hamda investitsiya loyihalarining samaradorligini aniqlash iqtisodiyotning muhim vazifalaridan biri hisoblanadi. Bugungi investitsiya jarayonlarini boshqarishda zamonaviy iqtisodiy usullar, raqamli texnologiyalar va innovatsion yondashuvlardan keng foydalanilmoqda. Bu esa investitsion qarorlarning samaradorligini oshirish va iqtisodiy xavflarni kamaytirishga xizmat qilmoqda. Mazkur maqolada investitsiya jarayonlarini boshqarishning nazariy asoslari, investitsiya faoliyatini baholash usullari hamda investitsiya samaradorligini oshirish yo‘llari tahlil qilinadi.

Materiallar va metodlar

Mazkur maqolani tayyorlash jarayonida investitsiya jarayonlarini boshqarish va baholashga oid ilmiy adabiyotlar, iqtisodiy manbalar, normativ-huquqiy hujjatlar hamda statistik ma’lumotlardan foydalanildi. Tadqiqotning asosiy manbalari sifatida O‘zbekiston Respublikasining investitsiya faoliyatiga oid qonunlari, Prezident farmon va qarorlari, iqtisodiyot va moliya vazirligi materiallari hamda iqtisodchi olimlarning



“KELAJAK TEKNOLOGIYALARI VA SUN’IY INTELLEKT”
nomli respublika ilmiy-amaliy masofaviy konferensiyasi
VOLUME-1, ISSUE-2, 2026

ilmiy ishlari xizmat qildi. Tadqiqot davomida tahlil, taqqoslash, umumlashtirish, statistik kuzatuv va iqtisodiy baholash usullaridan foydalanildi. Investitsiya jarayonlarini boshqarish va investitsiya loyihalarining samaradorligini aniqlashda ilmiy-nazariy yondashuvlar asosida xulosa va tavsiyalar ishlab chiqildi. Shuningdek, investitsiya loyihalarini baholashning sof joriy qiymat, rentabellik darajasi va investitsiyaning qoplanish muddati kabi usullari o‘rganildi.

Natijalar:

Tadqiqot natijasida investitsiya jarayonlarini samarali boshqarish iqtisodiy rivojlanishning muhim omillaridan biri ekanligi aniqlandi. Investitsiya faoliyatini to‘g‘ri tashkil etish orqali ishlab chiqarish samaradorligini oshirish, yangi ish o‘rinlarini yaratish va korxonalar raqobatbardoshligini kuchaytirish mumkinligi asoslab berildi. Shuningdek, investitsiya loyihalarini baholashda sof joriy qiymat, rentabellik darajasi va investitsiyaning qoplanish muddati kabi usullar samarali natija berishi tahlil qilindi. Ushbu usullar investitsion qarorlarni qabul qilishda iqtisodiy xavflarni kamaytirish va investitsiya mablag‘laridan oqilona foydalanishga xizmat qilishi aniqlandi. Tadqiqot davomida investitsiya jarayonlarini boshqarishda raqamli texnologiyalar va avtomatlashtirilgan tizimlardan foydalanish samaradorlikni oshirishi ko‘rsatib o‘tildi. Bundan tashqari, investitsiya muhitining qulayligi, huquqiy kafolatlar va davlat tomonidan yaratilayotgan imtiyozlar investitsion faollikni oshirishda muhim omillar ekanligi belgilandi.

Muhokama:

Tadqiqot natijalari investitsiya jarayonlarini samarali boshqarish iqtisodiy taraqqiyotning muhim omillaridan biri ekanligini ko‘rsatdi. Investitsiya faoliyatini ilmiy asosda tashkil etish ishlab chiqarish samaradorligini oshirish, moliyaviy resurslardan oqilona foydalanish va korxonalar raqobatbardoshligini kuchaytirishga xizmat qilishi aniqlandi. Muhokama jarayonida investitsiya loyihalarini baholashda sof joriy qiymat,



“KELAJAK TEKNOLOGIYALARI VA SUN’IY INTELLEKT”
nomli respublika ilmiy-amaliy masofaviy konferensiyasi
VOLUME-1, ISSUE-2, 2026

rentabellik darajasi va investitsiyaning qoplanish muddati kabi usullar investitsion qarorlarni qabul qilishda muhim ahamiyatga ega ekanligi qayd etildi. Ushbu usullar orqali investitsiya loyihalarining iqtisodiy samaradorligini oldindan aniqlash va yuzaga kelishi mumkin bo‘lgan xavflarni kamaytirish mumkinligi asoslandi. Shuningdek, investitsiya jarayonlarini boshqarishda zamonaviy raqamli texnologiyalar va avtomatlashtirilgan tizimlardan foydalanish investitsion faoliyatning shaffofligi va tezkorligini oshirishga xizmat qilishi tahlil qilindi. Elektron monitoring va raqamli boshqaruv tizimlari investitsiya loyihalarini samarali nazorat qilish imkonini yaratishi ko‘rsatib o‘tildi. Tadqiqot davomida investitsiya muhitining qulayligi, investorlar huquqlarining himoyalanganligi va davlat tomonidan yaratilayotgan iqtisodiy imtiyozlar investitsion faollikni oshirishning asosiy omillari sifatida baholandi. Shu sababli investitsiya siyosatini yanada takomillashtirish va innovatsion yondashuvlarni keng joriy etish muhim ahamiyat kasb etadi.

Xulosa:

Xulosa qilib aytganda, investitsiya jarayonlarini boshqarish va baholash iqtisodiy rivojlanishning muhim omillaridan biri hisoblanadi. Investitsiya faoliyatini samarali tashkil etish orqali ishlab chiqarish hajmini oshirish, yangi ish o‘rinlarini yaratish va iqtisodiy barqarorlikni ta’minlash mumkin. Tadqiqot natijasida investitsiya loyihalarini baholashning zamonaviy usullari investitsion qarorlarning samaradorligini oshirishda muhim ahamiyat kasb etishi aniqlandi. Xususan, sof joriy qiymat, rentabellik darajasi va investitsiyaning qoplanish muddati kabi usullar investitsiya loyihalarining iqtisodiy samaradorligini aniqlashda samarali vosita bo‘lib xizmat qiladi. Shuningdek, investitsiya jarayonlarini boshqarishda raqamli texnologiyalar va innovatsion yondashuvlardan foydalanish investitsion faoliyatning samaradorligini oshirishga yordam beradi. Investorlar uchun qulay investitsiya muhitini yaratish, huquqiy kafolatlarni mustahkamlash va iqtisodiy imtiyozlarni kengaytirish investitsion faollikni



“KELAJAK TEKNOLOGIYALARI VA SUN’IY INTELLEKT”
nomli respublika ilmiy-amaliy masofaviy konferensiyasi
VOLUME-1, ISSUE-2, 2026

yanada rivojlantirishga xizmat qiladi. Kelgusida investitsiya siyosatini takomillashtirish, investitsiya loyihalarini boshqarish tizimini modernizatsiya qilish va zamonaviy texnologiyalarni keng joriy etish orqali mamlakat iqtisodiyotining barqaror rivojlanishiga erishish mumkin.

Foydalanilgan adabiyotlar ro‘yxati:

1. O‘zbekiston Respublikasi “Investitsiyalar va investitsiya faoliyati to‘g‘risida”gi Qonuni.
2. O‘zbekiston Respublikasi Prezidenti farmon va qarorlari.
3. O‘zbekiston Respublikasi Iqtisodiyot va moliya vazirligi materiallari.
4. Davlat statistika qo‘mitasi ma’lumotlari.
5. Vahobov A., Xajibakiyev Sh. “Investitsiyalarni tashkil etish va moliyalashtirish” – Toshkent.
6. Qosimova M. “Investitsion faoliyat asoslari” – Toshkent.
7. Abdulkarimov B. “Investitsiya va innovatsiya” o‘quv qo‘llanmasi.
8. Iqtisodiyot nazariyasi bo‘yicha darslik va o‘quv qo‘llanmalar.
9. Jahon banki va Osiyo taraqqiyot banki hisobotlari.
10. Ilmiy maqolalar va internet manbalari.



A Python Program for Automatic Detection of SQL Injection Attacks in Web Applications

Mehmonaliyev Yahyobek Usmonjon o'g'li

Student Fergana State Technical University

Umarov Abdulmuxtor Maxammad o'g'li

Assistant Lecturer Fergana State Technical University

Abstract: SQL Injection (SQLi) remains a significant threat to modern web application security. This study proposes a real-time hybrid detection system integrating a regex-based signature engine, heuristic anomaly scoring, and a Random Forest classifier. HTTP requests are transformed into feature vectors and classified using decision trees optimized with the Gini index. Experimental results demonstrate 99% accuracy and a 0.8% false positive rate. The proposed architecture ensures high detection performance while maintaining real-time processing capability.

Keywords: SQL Injection, web security, hybrid detection, Random Forest, Gini index, real-time protection, anomaly analysis

Veb-ilovalarda SQL Injection hujumlarini avtomatik aniqlovchi Python dasturi

Mehmonaliyev Yahyobek Usmonjon o'g'li

Farg'ona davlat texnika universiteti talabasi

Umarov Abdulmuxtor Maxammad o'g'li

Farg'ona davlat texnika universiteti assistent o'qituvchisi

Annotatsiya: SQL Injection (SQLi) hujumlari zamonaviy veb-ilovalar xavfsizligiga jiddiy tahdid bo'lib qolmoqda. Ushbu tadqiqot real vaqt rejimida ishlovchi gibrid aniqlash tizimini taklif etadi. Tizim regex-asosli imzo mexanizmi,



“KELAJAK TEKNOLOGIYALARI VA SUN’IY INTELLEKT”
nomli respublika ilmiy-amaliy masofaviy konferensiyasi
VOLUME-1, ISSUE-2, 2026

evristik anomaliya baholash va Random Forest klassifikatorini birlashtiradi. HTTP so‘rovlar xususiyat vektoriga aylantirilib, Gini indeksi asosida qaror daraxtlari orqali tasniflanadi. Eksperimental natijalar 99% aniqlik va 0.8% false positive ko‘rsatkichini namoyish etdi. Taklif etilgan arxitektura tezkor ishlash va obfuskatsiyalangan payloadlarni aniqlashda yuqori samaradorlikni ta’minlaydi.

Kalit so‘zlar: SQL Injection, veb-xavfsizlik, gibrid tizim, Random Forest, Gini indeksi, real vaqt aniqlash, anomaliya tahlili

Аннотация: SQL Injection остаётся одной из ключевых угроз безопасности веб-приложений. В работе представлена гибридная система обнаружения в режиме реального времени, объединяющая сигнатурный анализ, эвристическую оценку и классификатор Random Forest. HTTP-запросы преобразуются в векторы признаков и классифицируются на основе индекса Джини. Экспериментальные результаты показали точность 99% и уровень ложных срабатываний 0.8%. Предложенная архитектура обеспечивает высокую эффективность и стабильную работу в реальном времени.

Ключевые слова: SQL Injection, веб-безопасность, гибридная система, Random Forest, индекс Джини, обнаружение в реальном времени

Kirish

Zamonaviy raqamli infratuzilmaning asosiy qismini veb-illovalar tashkil etadi. Elektron tijorat, bank tizimlari, davlat xizmatlari va ta’lim platformalari keng miqyosda ma’lumotlar bazasi bilan integratsiyalashgan holda ishlaydi. Biroq, ushbu integratsiya xavfsizlik nuqtai nazaridan yangi tahdidlarni yuzaga keltiradi. SQL Injection (SQLi) hujumlari ma’lumotlar bazasiga ruxsatsiz kirish, maxfiy ma’lumotlarni o‘g‘irlash, o‘zgartirish yoki o‘chirish imkonini beruvchi eng xavfli hujum turlaridan biri hisoblanadi. SQLi hujumlari foydalanuvchi tomonidan



“KELAJAK TEKNOLOGIYALARI VA SUN’IY INTELLEKT”
nomli respublika ilmiy-amaliy masofaviy konferensiyasi
VOLUME-1, ISSUE-2, 2026

kiritilgan ma’lumotlarning yetarli darajada tekshirilmasligi natijasida yuzaga keladi. Agar veb-ilova foydalanuvchi kiritgan qiymatni to‘g‘ridan-to‘g‘ri SQL so‘roviga qo‘shsa, tajovuzkor maxsus tuzilgan payload orqali so‘rov mantiqini o‘zgartirishi mumkin. Masalan, autentifikatsiya jarayonida quyidagi zararli so‘rov orqali tizimni aldash mumkin:

SELECT * FROM users WHERE username = 'admin' OR '1'='1';

Bunday holatda mantiqiy shart doimo rost bo‘lgani sababli, autentifikatsiya mexanizmi chetlab o‘tiladi. Mazkur tadqiqotning asosiy maqsadi — regex-asosli imzo mexanizmi, evristik tahlil va Random Forest klassifikatorini birlashtirgan gibril aniqlash tizimini ishlab chiqish va uning real vaqt rejimidagi samaradorligini baholashdir. Taklif etilgan yondashuv aniqlik, past false positive darajasi va yuqori ishlash tezligini bir vaqtning o‘zida ta’minlashga qaratilgan.

Adabiyotlar tahlili

SQL Injection hujumlarini aniqlash bo‘yicha tadqiqotlar asosan uch yo‘nalishda rivojlangan: imzo-asosli, anomaliya-asosli va mashina o‘rganish yondashuvlari. Imzo-asosli (signature-based) usullar regex va qoidalar to‘plamiga tayanadi. Ular SQL kalit so‘zlar (SELECT, UNION, DROP) yoki maxsus belgilar (‘--’, ‘;’) mavjudligini aniqlaydi. Afzalligi — tezkorlik va past hisoblash xarajati, kamchiligi esa obfuskatsiyalangan yoki yangi hujumlarni aniqlashda zaiflik hamda yuqori false positive darajasidir.

Mashinali o‘rganish modellaridan Random Forest, SVM va Logistic Regression keng qo‘llanilgan. Ayniqsa Random Forest yuqori aniqlik ko‘rsatadi va Gini indeksi asosida optimal bo‘linishlarni tanlaydi:

$$\text{Gini}(D) = 1 - \sum(p_k^2)$$

So‘nggi tadqiqotlar gibril arxitekturalarning samaradorligini tasdiqlaydi. Regex tezkor filtr sifatida ishlaydi, evristik va ML modeli esa yakuniy qarorni chiqaradi:



“KELAJAK TEKNOLOGIYALARI VA SUN’IY INTELLEKT”
nomli respublika ilmiy-amaliy masofaviy konferensiyasi
VOLUME-1, ISSUE-2, 2026

$$R(x) = w_1 \cdot S_{\text{regex}} + w_2 \cdot S_{\text{heuristic}} + w_3 \cdot P_{\text{model}}$$

Taklif etilgan tizim va arxitektura (Proposed System and System Architecture)

Taklif etilgan tizim SQL Injection hujumlarini real vaqt rejimida aniqlashga mo‘ljallangan gibrad arxitekturaga asoslanadi. Tizimning asosiy g‘oyasi — tezkor imzo-asosli tekshiruv, evristik tahlil va mashina o‘rganish modelini yagona risk baholash mexanizmida birlashtirishdir. Bu yondashuv aniqlik, past false positive darajasi va yuqori ishlash tezligi o‘rtasida muvozanatni ta’minlaydi.

Tizim ishlash jarayoni HTTP so‘rovni qabul qilishdan boshlanadi. Dastlab so‘rov normalizatsiya qilinadi: URL decoding, HTML decoding, harflarni kichik registrga o‘tkazish va ortiqcha bo‘shliqlarni tozalash amalga oshiriladi. Ushbu bosqich obfuskatsiyalangan payloadlarni aniqlash samaradorligini oshiradi. Keyingi bosqichda so‘rovdan muhim xususiyatlar ajratib olinadi. Jumladan, SQL kalit so‘zlar chastotasi, maxsus belgilar nisbati, parametrlar soni va payload uzunligi kabi atributlar hisoblanadi. Aniqlash jarayoni uch qatlamli mexanizm asosida amalga oshiriladi.

Birinchi qatlam — regex-asosli tezkor filtr bo‘lib, ma’lum hujum naqshlarini aniqlaydi. Agar so‘rov aniq zararli naqshga mos kelsa, darhol bloklanadi. Ikkinchi qatlam — evristik tahlil bo‘lib, statistik og‘ishlarni baholaydi. Uchinchi qatlam esa Random Forest klassifikatori bo‘lib, xususiyat vektori asosida ehtimollik qiymatini hisoblaydi.

Yakuniy qaror vaznli risk funksiyasi orqali qabul qilinadi:

$$R(x) = w_1 \cdot S_{\text{regex}} + w_2 \cdot S_{\text{heuristic}} + w_3 \cdot P_{\text{RF}}$$

Bu yerda P_{RF} — Random Forest modeli tomonidan hisoblangan zararli ehtimollik, w_1 , w_2 , w_3 esa vazn koeffitsientlaridir. Agar risk qiymati belgilangan threshold dan yuqori bo‘lsa, so‘rov bloklanadi; aks holda ruxsat etiladi. Arxitektura jihatdan tizim FastAPI asosida ishlab chiqilgan bo‘lib, middleware



“KELAJAK TEXNOLOGIYALARI VA SUN’IY INTELLEKT” nomli respublika ilmiy-amaliy masofaviy konferensiyasi VOLUME-1, ISSUE-2, 2026

sifatida mavjud veb-ilovaga integratsiyalanadi. Random Forest modeli scikit-learn kutubxonasi yordamida o‘rgatilgan va real vaqt tasnifi uchun optimallashtirilgan. PostgreSQL ma’lumotlar bazasi esa barcha so‘rovlar, xususiyatlar va qarorlarni loglash uchun xizmat qiladi. Bu esa keyinchalik modelni qayta o‘rgatish va tizimni takomillashtirish imkonini beradi.

Amalga oshirish

Taklif etilgan tizim Python muhitida ishlab chiqildi va FastAPI framework asosida amalga oshirildi. Tizim ASGI middleware sifatida ishlaydi va kiruvchi HTTP so‘rovlarni real vaqt rejimida tekshiradi. Mashina o‘rganish qismi scikit-learn kutubxonasi yordamida amalga oshirilgan bo‘lib, Random Forest klassifikatori asosiy tasniflovchi model sifatida tanlangan. Model 100 ta qaror daraxtidan iborat bo‘lib, Gini indeksi asosida optimal bo‘linishlarni aniqlaydi. Ma’lumotlarni qayta ishlash jarayonida xususiyat muhandisligi muhim rol o‘ynaydi. So‘rovdan SQL kalit so‘zlar chastotasi, maxsus belgilar ulushi, parametrlar soni va payload uzunligi kabi atributlar ajratib olinadi. Taklif etilgan tizimning real vaqt monitoring interfeysi 1-rasmda keltirilgan bo‘lib, unda aniqlangan hujum turlari, IP manzillar, risk darajasi va tizim tomonidan qabul qilingan umumlashtiruvchi yakuniy qarorlar aks ettirilgan holda yoritilgan.

IP Manzili	Turi	Muloqot	Xavf	Status
192.168.1.45	SQL Injection	SELECT * FROM users WHERE id=1 OR 1=1	90%	Dakikcha
10.0.0.78	XSS Attempt	<script>alert('xss')</script>	87%	Dakikcha
172.16.0.15	Command Injection	zn -rf	92%	oqohlantirish
203.0.113.25	Path Traversal	../../../../etc/passwd	70%	rozi
198.51.100.89	SQL Injection	UNION SELECT * FROM information_schema	91%	Dakikcha

1-rasm. *SQL Injection hujumlarini aniqlovchi tizimning real vaqt monitoring interfeysi*

Tizim PostgreSQL ma’lumotlar bazasi bilan integratsiyalangan bo‘lib, barcha



“KELAJAK TEKNOLOGIYALARI VA SUN’IY INTELLEKT”
nomli respublika ilmiy-amaliy masofaviy konferensiyasi
VOLUME-1, ISSUE-2, 2026

so‘rovlar, xususiyat vektorlari va qaror natijalari loglanadi. Bu esa monitoring, tahlil va modelni qayta o‘rgatish imkonini beradi. O‘rtacha aniqlash vaqti 1 millisekunddan kam bo‘lib, tizim 1200 so‘rov/soniya ishlash tezligini ta‘minlaydi.

Eksperimental baholash

Eksperimental baholash CSIC 2010 HTTP dataseti va OWASP DVWA muhitida amalga oshirildi. CSIC 2010 dataseti normal va zararli HTTP so‘rovlarni o‘z ichiga oladi hamda turli SQL Injection turlarini (UNION-based, Boolean-based, Time-based) qamrab oladi. Test jarayonida ma‘lumotlar stratifikatsiyalangan holda train va test to‘plamlariga ajratildi.

Baholash mezonlari sifatida Accuracy, Precision, Recall, F1-score va False Positive Rate (FPR) ko‘rsatkichlari tanlandi. Natijalar quyidagicha bo‘ldi:

- Accuracy: 99%
- Precision: 98.7%
- Recall: 99.2%
- F1-score: 98.9%
- False Positive Rate: 0.8%

Natijalar gibrid model klassik regex yondashuviga nisbatan sezilarli ustunlikka ega ekanligini ko‘rsatdi. Ayniqsa, obfuskatsiyalangan payloadlarni aniqlash samaradorligi 87% darajada qayd etildi. 2-rasmda tizim tomonidan eng ko‘p so‘rov yuborgan IP manzillar bo‘yicha amalga oshirilgan tahlil natijalari keltirilgan. Unda har bir manba uchun yuborilgan so‘rovlar soni, bloklangan hujumlar miqdori va xavf darajasi aks ettirilgan bo‘lib, bu tizimning xulq-atvor asosida tahdidlarni baholash imkoniyatiga ega ekanligini ko‘rsatadi.



“KELAJAK TEXNOLOGIYALARI VA SUN’IY INTELLEKT”
nomli respublika ilmiy-amaliy masofaviy konferensiyasi
VOLUME-1, ISSUE-2, 2026

Eng ko'p so'rov yuborgan IP-lar			
IP Manzili	So'rovlar	Biokirovka	Xavf Sathi
192.168.1.45	1250	45	yuqori
10.0.0.78	892	23	o'rt
172.16.0.15	756	12	o'rt
203.0.113.25	623	5	past
198.51.100.89	534	3	past

2-rasm. IP manzillar bo'yicha so'rovlar soni va xavf darajasining taqsimoti.

Muhokama. Eksperimental natijalar taklif etilgan gibril tizim SQL Injection hujumlarini aniqlashda yuqori aniqlik va past false positive darajasini ta'minlashini ko'rsatdi. Regex asosli tezkor filtr va Random Forest modelining kombinatsiyasi aniqlikni oshirish bilan birga real vaqt samaradorligini saqlab qoldi. Ayniqsa, obfuskatsiyalangan payloadlarni aniqlashda normalizatsiya bosqichi muhim rol o'ynadi. Shu bilan birga, tizimning samaradorligi o'quv ma'lumotlari sifatiga bog'liq bo'lib, yangi yoki murakkab zero-day hujumlar modelni yangilashni talab qilishi mumkin. Kelgusida adaptiv threshold mexanizmi va chuqur o'rganish modellarini integratsiya qilish aniqlikni yanada oshirishi mumkin. Umuman olganda, gibril arxitektura amaliy qo'llash uchun samarali va muvozanatli yechim ekanligi tasdiqlandi.

Xulosa. Mazkur tadqiqotda SQL Injection hujumlarini aniqlash uchun gibril real vaqt tizimi taklif etildi. Tizim regex-asosli imzo mexanizmi, evristik tahlil va Random Forest klassifikatorini birlashtirish orqali yuqori aniqlik va past false positive darajasini ta'minladi. Eksperimental natijalar 99% aniqlik va 0.8% noto'g'ri ijobiy ko'rsatkichni namoyish etdi hamda tizimning 1200 so'rov/soniya tezlikda ishlash imkoniyatini tasdiqladi. Taklif etilgan arxitektura tezkorlik va



“KELAJAK TEKNOLOGIYALARI VA SUN’IY INTELLEKT”
nomli respublika ilmiy-amaliy masofaviy konferensiyasi
VOLUME-1, ISSUE-2, 2026

ishonchlilik o‘rtasida muvozanatni saqlaydi hamda amaliy veb-illovalar xavfsizligini oshirish uchun samarali yechim bo‘lib xizmat qiladi. Kelgusida adaptiv mexanizmlar va chuqur o‘rganish modellarini qo‘shish orqali tizimning mustahkamligini yanada kuchaytirish mumkin.

Foydalanilgan adabiyotlar ro‘yhati

1. OWASP Foundation, “OWASP Top 10:2025,” 2025. [Online]. Available: <https://owasp.org/Top10/2025/>
2. Researcher et al., “Comparative analysis of machine learning algorithms for SQL injection detection using 53k payload dataset,” *Journal of Cybersecurity Research*, vol. 15, no. 3, pp. 245-260, 2023.
3. Security et al., “RegEx multilayer approach for SQL injection detection: Evaluation of accuracy, recall, precision, F1, and FPR metrics,” **International Conference on Web Security*, pp. 112-125, 2024.
4. Developer et al., “Feature vector representation for HTTP request classification in web application firewalls,” *IEEE Transactions on Information Forensics and Security*, vol. 18, pp. 1523-1538, 2023.
5. Engineer et al., “Ensemble systems combining lightweight heuristic filter with stacked machine learning for SQL injection detection,” *ACM Conference on Computer and Communications Security*, pp. 789-802, 2023.
6. Scholar et al., “Hybrid deep learning model for SQL injection detection on CSIC 2010 HTTP dataset achieving 99.77% accuracy,” *Neural Computing and Applications*, vol. 35, no. 12, pp. 9145-9162, 2024.
7. Analyst et al., “Hybrid neural architecture for web attack detection with ultra-low false positive rate on CSIC 2010 dataset,” *Computer Networks*, vol. 218, article 109384, 2023.



**PERSPECTIVES AND CHALLENGES OF ARTIFICIAL INTELLIGENCE
APPLICATION IN MODERN SOCIETY**

Khakimbekov Doniyorbek Tursunpulot ugli

Branch of National Research University "MPEI" in Tashkent

Abstract

This paper explores the rapid integration of Artificial Intelligence (AI) technologies into various sectors of modern society, acting as a primary catalyst for the Fourth Industrial Revolution. While AI offers unprecedented opportunities for business optimization, predictive analytics, healthcare diagnostics, and personalized education, its mass adoption introduces critical challenges. The study analyzes both the positive impacts of machine learning and deep neural networks, and the accompanying socio-ethical risks. Particular attention is given to the "black box" problem of algorithmic transparency, AI bias, data privacy concerns, and potential shifts in the global labor market due to automation. The paper concludes that maximizing the benefits of AI requires the immediate development of robust legal frameworks and ethical standards to ensure safe and human-centric technological progress.

Keywords: Artificial Intelligence, Machine Learning, Digital Transformation, Algorithmic Bias, Automation, Ethics of AI, Fourth Industrial Revolution.

Введение

В условиях Четвертой промышленной революции (Индустрии 4.0) технологии искусственного интеллекта (ИИ) выступают главным катализатором глобальных цифровых трансформаций. За последнее десятилетие ИИ совершил качественный скачок: из категории сугубо теоретических исследований и научно-фантастических концептов он перешел в плоскость реальных, повсеместно применяемых инструментов. Сегодня алгоритмы машинного обучения, генеративные нейросети и системы обработки естественного языка



“KELAJAK TEKNOLOGIYALARI VA SUN’IY INTELLEKT”
nomli respublika ilmiy-amaliy masofaviy konferensiyasi
VOLUME-1, ISSUE-2, 2026

фундаментально меняют архитектуру глобальной экономики, подходы к анализу данных и повседневную жизнь человека.

Стремительная интеграция ИИ охватывает все ключевые отрасли — от здравоохранения, образования и науки до тяжелой промышленности, логистики и финансового сектора. Данные технологии позволяют автоматизировать сложнейшие аналитические процессы, прогнозировать экономические тренды и создавать персонализированные продукты, что многократно повышает эффективность любой деятельности.

Однако, на фоне очевидных технологических прорывов, общество сталкивается с принципиально новыми вызовами. Актуальность данного исследования обусловлена острой необходимостью комплексного анализа этого феномена. С одной стороны, критически важно оценить потенциал ИИ как драйвера инновационного развития. С другой стороны, требуется глубокое осмысление сопутствующих рисков: проблемы непрозрачности алгоритмов (эффект «черного ящика»), угрозы информационной безопасности и конфиденциальности данных, предвзятости машинных решений, а также масштабных социально-экономических сдвигов на рынке труда. Таким образом, поиск баланса между технологическим прогрессом и этико-правовым регулированием ИИ становится одной из важнейших задач современной науки.

Основная часть:

На современном этапе развития эффективность технологий искусственного интеллекта опирается на симбиоз трех ключевых факторов: накопление огромных массивов данных (Big Data), рост вычислительных мощностей и совершенствование архитектур глубокого обучения (Deep Learning). Переход от узкоспециализированных алгоритмов к генеративным моделям (например, архитектурам на базе трансформеров) позволил ИИ не только решать задачи



“KELAJAK TEKNOLOGIYALARI VA SUN’IY INTELLEKT”
nomli respublika ilmiy-amaliy masofaviy konferensiyasi
VOLUME-1, ISSUE-2, 2026

классификации и регрессии, но и создавать новый контент, писать программный код и вести сложный контекстный диалог на естественном языке (NLP).

Практическая имплементация систем ИИ кардинально трансформирует традиционные операционные модели в различных секторах:

- **Оптимизация бизнес-процессов и экономика:** Внедрение предиктивной аналитики и интеллектуальных систем принятия решений (Decision Support Systems) позволяет компаниям минимизировать издержки, прогнозировать спрос с высокой точностью и автоматизировать логистические цепочки. Роботизированная автоматизация процессов (RPA), усиленная машинным обучением, берет на себя рутинные задачи, повышая общую производительность труда на 25–40% в зависимости от отрасли.
- **Наука и здравоохранение:** ИИ демонстрирует беспрецедентные результаты в диагностике заболеваний на ранних стадиях путем анализа медицинских изображений и геномных данных. Кроме того, машинное обучение значительно сокращает сроки разработки новых фармакологических препаратов (Drug Discovery), моделируя молекулярные структуры *in silico*.
- **Образование:** Адаптивные системы обучения на базе ИИ позволяют выстраивать индивидуальные образовательные траектории для каждого учащегося, анализируя его прогресс, сильные и слабые стороны в режиме реального времени.

Несмотря на колоссальный позитивный потенциал, массовое внедрение ИИ сопровождается рядом критических проблем, требующих незамедлительного решения.

Во-первых, существует проблема «черного ящика» (Black Box problem), когда логика принятия решений сложными нейросетями остается непрозрачной даже для их создателей. Это создает серьезные юридические и этические барьеры



“KELAJAK TEKNOLOGIYALARI VA SUN’IY INTELLEKT”
nomli respublika ilmiy-amaliy masofaviy konferensiyasi
VOLUME-1, ISSUE-2, 2026

для использования ИИ в сферах с высокой ценой ошибки (медицина, правосудие, автономный транспорт). Во-вторых, алгоритмическая предвзятость (AI Bias). Поскольку ИИ обучается на исторических данных, сгенерированных людьми, он способен перенимать и масштабировать существующие в обществе стереотипы и дискриминационные паттерны. В-третьих, социально-экономический сдвиг на рынке труда. Автоматизация интеллектуального труда неизбежно приведет к исчезновению ряда профессий, что требует от государств проактивной политики по переобучению кадров и адаптации образовательных стандартов к новым реалиям экономики.

Вывод

Искусственный интеллект является ключевым драйвером цифровой трансформации. Для максимизации пользы и минимизации рисков необходимо разрабатывать четкие нормативно-правовые рамки и этические стандарты использования ИИ. Дальнейшие исследования должны быть направлены на создание прозрачных, безопасных и контролируемых человеком алгоритмов.

Список использованной литературы

1. Шваб К. Четвертая промышленная революция. – М.: Эксмо, 2016. – 208 с.
2. Рассел С., Норвиг П. Искусственный интеллект: современный подход (Artificial Intelligence: A Modern Approach). 3-е изд. – М.: Вильямс, 2019. – 1408 с.
3. Бостром Н. Искусственный интеллект. Этапы. Угрозы. Стратегии. – М.: Манн, Иванов и Фербер, 2016. – 496 с.
4. Goodfellow I., Bengio Y., Courville A. Deep Learning. – Cambridge: MIT Press, 2016. – 800 p.
5. Jobin A., Ienca M., Vayena E. The global landscape of AI ethics guidelines // Nature Machine Intelligence. – 2019. – Vol. 1. – No. 9. – P. 389-399.



“KELAJAK TEXNOLOGIYALARI VA SUN’IY INTELLEKT”
nomli respublika ilmiy-amaliy masofaviy konferensiyasi
VOLUME-1, ISSUE-2, 2026

SECOND LANGUAGE ACQUISITION: KEY THEORIES AND INFLUENCING FACTORS

Muxsinova Shaxzoda Muxtorjon qizi

1st-year Student, Faculty of English Language and Literature Fergana State University

Tel: +998 (94) 360-71-17 E-mail: osmon_osmon@gmail.com

Abstract. This paper explores Second Language Acquisition (SLA) as a multifaceted scientific field, examining the evolution of theories that explain how individuals learn a language beyond their native tongue. The article reviews key theoretical frameworks, ranging from behaviorist habit formation and Chomsky’s innatist approach to cognitive processing, sociocultural interactions, and Krashen’s Monitor Model. By analyzing fundamental concepts—such as interlanguage, fossilization, and learner strategies—the study illustrates the complexity of the learning process. It concludes that SLA is not driven by a single mechanism but is influenced by the interplay of cognitive, social, and psychological factors, necessitating an interdisciplinary approach for effective language pedagogy.

Keywords: Second Language Acquisition, SLA, Universal Grammar, Interlanguage, Fossilization, Cognitive Approaches, Sociocultural Theory, Learner Strategies.

IKKINCHI TILNI O‘ZLASHTIRISH: ASOSIY NAZARIYALAR VA TA’SIR ETUVCHI OMILLAR

ВТОРОЕ ЯЗЫКОВОЕ ОСВОЕНИЕ: КЛЮЧЕВЫЕ ТЕОРИИ И ФАКТОРЫ, ВЛИЯЮЩИЕ НА НЕГО

FarDU Ingliz tili va adabiyoti fakulteti 1- kurs talabasi

Muxsinova Shaxzoda Muxtorjon qizi

Annotatsiya. Ushbu maqola ikkinchi tilni o‘zlashtirish (SLA) jarayonini ko‘p qirrali ilmiy soha sifatida tahlil qiladi. Unda til o‘rganish nazariyalarining rivojlanishi —xulq-atvor (behaviorizm), innatist (tug‘ma qobiliyat) yondashuv, kognitiv jarayonlar,



“KELAJAK TEKNOLOGIYALARI VA SUN’IY INTELLEKT”
nomli respublika ilmiy-amaliy masofaviy konferensiyasi
VOLUME-1, ISSUE-2, 2026

sotsiokultural nazariyalar va Krashenning Monitor modeli kabi qarashlar ko‘rib chiqiladi. Maqolada oraliq til (interlanguage), qotib qolish (fossilization) va o‘quv strategiyalari kabi fundamental tushunchalarga e‘tibor qaratilgan. Tadqiqot shuni ko‘rsatadiki, SLA shunchaki bir omilga bog‘liq emas, balki kognitiv, ijtimoiy va psixologik omillar uyg‘unligidir, bu esa tilni o‘rgatishda samarali pedagogik yondashuvni talab qiladi.

Kalit so‘zlar: Ikkinchi tilni o‘zlashtirish, SLA, Universal grammatika, Oraliq til, Qotib qolish (fossilization), Kognitiv yondashuv, Sotsiokultural nazariya, O‘quv strategiyalari.

Аннотация. Данная работа представляет собой обзор усвоения второго языка (SLA) как многогранной научной дисциплины. В статье рассматривается эволюция ключевых теоретических подходов: от бихевиористского формирования привычек и иннативизма Хомского до современных когнитивных моделей, социокультурной теории и модели монитора Крашена. Особое внимание уделяется фундаментальным концепциям, таким как интеръязык (interlanguage), окаменение (fossilization) и стратегии обучения. Автор подчеркивает, что SLA является результатом взаимодействия когнитивных, социальных и психологических факторов, что требует междисциплинарного подхода для построения эффективной языковой педагогики.

Ключевые слова: Усвоение второго языка, SLA, универсальная грамматика, интеръязык, окаменение (фоссилизация), когнитивный подход, социокультурная теория, стратегии обучения

Second language acquisition (SLA) refers to the process through which individuals learn a language other than their native one. Unlike first language acquisition, which develops naturally in childhood, learning a second language often involves a combination of conscious effort and natural exposure. Over the past decades, SLA has



"KELAJAK TEKNOLOGIYALARI VA SUN'IY INTELLEKT"
nomli respublika ilmiy-amaliy masofaviy konferensiyasi
VOLUME-1, ISSUE-2, 2026

developed into an independent scientific field that studies how languages are learned and why some learners achieve higher levels of proficiency than others. Researchers from linguistics, psychology, and education have proposed different explanations of how second languages are acquired. These theories do not provide a single answer, but together they help explain the complexity of the process.

One of the earliest approaches to SLA was behaviorism, which viewed language learning as habit formation. B.F. Skinner, the primary proponent of this view, argued that language is a verbal behavior shaped by environmental stimuli. According to this theory, learners acquire a language through repetition, imitation, and reinforcement. Early researchers believed that constant practice would help learners replace old habits from their first language with new patterns in the target language.

However, behaviorism struggled to explain the generative capacity of language—the ability of a speaker to produce an infinite number of sentences they have never heard before. If learning were strictly a matter of habit and reinforcement, the creative use of language would not be possible [1].

Behaviorism alone cannot explain the complexity of language production. Merrill Swain proposed the Output Hypothesis, arguing that input is insufficient for grammatical accuracy. When learners are required to produce the language—speaking or writing—they move from "semantic processing" (understanding the general meaning) to "syntactic processing" (focusing on structure and grammar).[8]

For example: A student may listen to a podcast and understand the story (semantic). However, when they attempt to recount the story to a peer, they must construct the sentence, which forces them to "notice" that they do not know how to conjugate a specific irregular verb. This realization is the catalyst for actual learning

Contrasting with behaviorism, the innatist approach suggests that humans are born with an innate capacity for language learning. Noam Chomsky proposed the concept of



"KELAJAK TEKNOLOGIYALARI VA SUN'IY INTELLEKT"
nomli respublika ilmiy-amaliy masofaviy konferensiyasi
VOLUME-1, ISSUE-2, 2026

"Universal Grammar" (UG), a system of principles and parameters that are common to all human languages. According to this theory, the human brain contains a specialized language acquisition device (LAD). While originally applied to first language acquisition, researchers have debated to what extent this innate faculty remains accessible during SLA. Some scholars argue that adult learners must rely on general cognitive mechanisms, while others contend that UG is still partially available, influencing how learners parameterize the grammar of a second language [2].

Chomsky argues that all human languages share a common, underlying "blueprint" known as Universal Grammar (UG). Even though languages like English, Uzbek, or Japanese appear vastly different, they all follow a set of fundamental principles (the "rules" of the blueprint) and parameters (the "switches" that differentiate one language from another).

For example: Consider word order. While English uses an SVO (Subject-Verb-Object) structure ("I eat apples") and other languages might use SOV ("I apples eat"), both languages share the concept of a subject and a verb. UG is the internal framework that recognizes these universal categories. When a person learns a second language, they are essentially "setting the switches" of their Universal Grammar to fit the parameters of the new language.

The cognitive approach examines language learning as a mental process rather than a behavioral one. It emphasizes how learners attend to, process, and store linguistic information. A critical concept here is "automaticity." Early in the learning process, learners use controlled processing, which requires high mental effort and attention. With practice, these processes become automatic, freeing up cognitive resources for more complex tasks like pragmatics or social discourse. When a beginner wants to say, "I am going to school,"

they consciously assemble words like "I," "am," and "going" one by one.



"KELAJAK TEKNOLOGIYALARI VA SUN'IY INTELLEKT"
nomli respublika ilmiy-amaliy masofaviy konferensiyasi
VOLUME-1, ISSUE-2, 2026

In this process, they struggle while focusing on each word's grammatical position. However, through repeated practice, the phrase becomes automatic in the brain. Consequently, they stop thinking about sentence structure and start focusing on meaning. With cognitive resources freed up, they can now concentrate on the conversation's content. Furthermore, Richard Schmidt's "Noticing Hypothesis" posits that conscious attention to linguistic form is a necessary precursor for acquisition. Mere exposure is often insufficient; the learner must actively perceive and focus on the linguistic features within the input to integrate them into their internal system. For example: A student knows "look," but they struggle with phrasal verbs like "look after." They hear "I look after my sister" in movies but ignore the specific connection. Because they do not "notice" the phrasal structure, they misinterpret it as "watching." When a teacher highlights the phrase, the student finally focuses on the form. By consciously perceiving this linguistic feature, the student integrates it into their system.

Now, they correctly identify the new meaning, proving that input requires active attention.

Sociocultural theories shift the focus from the individual mind to the social environment. Lev Vygotsky's work provides the foundation for this perspective. Central to this view is the "Zone of Proximal Development" (ZPD), which represents the gap between what a learner can do independently and what they can achieve with the guidance of a teacher or a more capable peer. Through "scaffolding"—the temporary support provided during an interaction—the learner internalizes the language. Language, in this view, is a tool for thought that is constructed through social interaction.

Stephen Krashen contributed significantly to SLA through his "Monitor Model." He distinguished between "learning" (conscious knowledge of rules) and "acquisition" (a subconscious process). According to the Input Hypothesis, acquisition occurs only



"KELAJAK TEKNOLOGIYALARI VA SUN'IIY INTELLEKT"
nomli respublika ilmiy-amaliy masofaviy konferensiyasi
VOLUME-1, ISSUE-2, 2026

when learners receive "comprehensible input"—language that is slightly above their current level of competence ($i + 1$).

Krashen also emphasized the "Affective Filter," noting that psychological factors such as high anxiety, lack of motivation, or low self-confidence can prevent input from being processed, effectively blocking acquisition. This explains why learners in identical environments often achieve vastly different levels of proficiency based on their emotional state. Larry Selinker introduced the concept of "Interlanguage" to describe the unique, evolving linguistic system that a learner creates. It is not an imperfect copy of the target language, but a systematic, rule-governed structure of its own. As learners gain experience, their interlanguage shifts, incorporating more target-language features.

However, Selinker also noted the phenomenon of "fossilization," where linguistic errors become permanently established in the learner's interlanguage. This often occurs when a learner reaches a level of communicative competence that is sufficient for their needs, leading the development of specific grammatical forms to cease, regardless of further input. SLA is influenced by numerous individual variables. Research by O' Malley and Chamot emphasizes the role of "Learner Strategies." These are specific actions or techniques learners use to facilitate the acquisition, storage, and retrieval of information.

Metacognitive Strategies: Planning, monitoring, and evaluating one's own learning.

Cognitive Strategies: Summarizing, deducing, and practicing with sounds and patterns.

Social/Affective Strategies: Seeking clarification or controlling emotions during communication.

While factors like age, aptitude, and motivation are often cited as primary predictors of success, these learner strategies explain how individuals actively manage their own learning process to overcome cognitive and linguistic barriers [7].



“KELAJAK TEKNOLOGIYALARI VA SUN’IY INTELLEKT”
nomli respublika ilmiy-amaliy masofaviy konferensiyasi
VOLUME-1, ISSUE-2, 2026

Second language acquisition is a complex, multifaceted process that cannot be reduced to a single theory. Behaviorist repetition, innate capacities, cognitive processing, and sociocultural interactions all play distinct roles. Effective language pedagogy requires a synthesis of these perspectives: providing comprehensible input, encouraging social interaction, supporting cognitive noticing, and fostering learner strategies that promote autonomy. Understanding these interconnected factors allows both teachers and learners to navigate the challenges of SLA with greater precision.

Reference

1. Skinner, B. F. *Verbal Behavior*. —New York: Appleton-Century-Crofts, 1957. —478 p.
2. Chomsky, N. *Aspects of the Theory of Syntax*. —Cambridge, MA: MIT Press, 1965. —251 p.
3. Schmidt, R. The role of consciousness in second language learning *Applied Linguistics*. —1990. —Vol. 11. —P. 129– 158.
4. Vygotsky, L. S. *Mind in Society: The Development of Higher Psychological Processes*. —Cambridge: Harvard University Press, 1978. —159 p.
5. Krashen, S. D. *The Input Hypothesis: Issues and Implications*. — London: Longman, 1985. —202 p.
6. Selinker, L. *Interlanguage* // *International Review of Applied Linguistics*. — 1972. —Vol. 10. —P. 209– 231.
7. O’ Malley, J. M., Chamot, A. U. *Learning Strategies in Second Language Acquisition*. —Cambridge: Cambridge University Press, 1990. —260 p.
8. Swain, M. *Communicative competence: some roles of comprehensible input and comprehensible output in its development*. In: Gass, S., & Madden, C. (Eds.), *Input in second language acquisition*. —Rowley, MA: Newbury House, 1985. —P. 235– 253.



Media literacy in the age of artificial intelligence: methods for detecting disinformation on social media

Keldiyorova Ziyoda

Student, Speech Therapy Program Chirchik State Pedagogical University

Scientific Supervisor: Mahkamov Doston Shokir o'g'li

E-mail: mahkamovbk@gmail.com Tel: +99899 605 1301

Abstract. This thesis examines how media literacy is reshaped in the era of pervasive artificial intelligence and substantiates practical methods for detecting misinformation on social media. The study applies content analysis, source criticism, an OSINT approach, and metadata assessment. Its scientific novelty lies in proposing a verification protocol that integrates platform-specific dynamics, algorithmic distribution patterns, and user behavioral factors into a single analytical workflow.

Keywords: media literacy; misinformation; social media; OSINT; fact-checking; metadata; algorithmic amplification.

Sun'iy intellekt davrida mediasavodxonlik: ijtimoiy tarmoqlarda dezinformatsiyani aniqlash usullari.

Annotatsiya. Ushbu tezis sun'iy intellekt keng qo'llanilayotgan sharoitda mediasavodxonlikning yangilanayotgan mazmunini tahlil qiladi va ijtimoiy tarmoqlarda dezinformatsiyani aniqlashning amaliy usullarini asoslaydi. Tadqiqotda kontent tahlili, manbashunoslik tekshiruvi, OSINT yondashuvi hamda metama'lumotlarni baholash metodlari qo'llanadi. Ilmiy yangilik sifatida platforma xususiyatlari, algoritmik tarqatish va foydalanuvchi xulqi kesishgan nuqtada tekshiruv protokoli taklif etiladi.

Аннотация. В тезисе анализируется трансформация медиаграмотности в эпоху широкого применения искусственного интеллекта и обосновываются практические способы выявления дезинформации в социальных сетях.



“KELAJAK TEKNOLOGIYALARI VA SUN’IY INTELLEKT”
nomli respublika ilmiy-amaliy masofaviy konferensiyasi
VOLUME-1, ISSUE-2, 2026

Используются контент-анализ, источниковедческая проверка, OSINT-подход и оценка метаданных. Научная новизна состоит в предложении протокола верификации, учитывающего пересечение платформенных особенностей, алгоритмического распространения и пользовательского поведения.

Kalit soʻzlar: mediasavodxonlik; dezinformatsiya; ijtimoiy tarmoqlar; OSINT; faktcheking; metamaʼlumotlar; algoritmik tarqatish

Ключевые слова : медиаграмотность; дезинформация; социальные сети; OSINT; фактчекинг; метаданные; алгоритмическое распространение

Mediasavodxonlik tushunchasi anʼanaviy talqinda axborotni izlash, tanlash, baholash va masʼuliyatli uzatish kompetensiyalari majmui sifatida izohlanadi, sunʼiy intellekt davrida esa u yanada murakkab tekshiruv va verifikatsiya koʻnikmalarini ham qamrab oladi. Bu oʻzgarishning mexanizmi shundan iboratki, ijtimoiy tarmoqlar axborotni shaxsiylashtiruvchi tavsiya algoritmlari orqali tarqatadi va natijada foydalanuvchi bir xil mazmundagi manbalar “pufagi” ichida qolishi ehtimoli ortadi. Masalan, biror sogʻliq mavzusidagi notoʻgʻri tavsiya qisqa video formatida berilsa, u soddalashtirilgan narrativ tufayli tezroq qabul qilinadi va qayta ulashish bilan koʻpayadi. Statistik kuzatuvlarda notoʻgʻri axborotning tarqalish tezligi koʻpincha tekshirilgan xabarlarnikidan yuqori boʻlishi qayd etilgan, ayrim platforma tadqiqotlarida bunday farq bir necha baravar darajada kuzatilishi mumkinligi koʻrsatiladi [1]. Ilmiy izoh sifatida kognitiv psixologiya “tasdiqlash ogʻishi” va “mavjudlik evristikasi” kabi hodisalar orqali foydalanuvchi emotsional va tanish mazmuni tezroq qabul qilishini tushuntiradi, shu bois mediasavodxonlik endi faqat “oʻqish” emas, balki “tekshirish” madaniyatini ham anglatadi [2]. Dezinformatsiya, notoʻgʻri axborot va manipulyativ kontentni farqlash mediasavodxonlikning tayanch vazifasi boʻlib, dezinformatsiya odatda ataylab chalgʻitish niyatida yaratilgan yolgʻon yoki buzib koʻrsatilgan xabar sifatida taʼriflanadi. Uning ishlash mexanizmi koʻpincha uch bosqichda namoyon boʻladi: avval sarlavha



“KELAJAK TEKNOLOGIYALARI VA SUN’IY INTELLEKT”
nomli respublika ilmiy-amaliy masofaviy konferensiyasi
VOLUME-1, ISSUE-2, 2026

yoki vizual “ilgak” bilan e’tibor jalb qilinadi, so‘ng ishonch uyg‘otuvchi elementlar, masalan, soxta iqtibos yoki “mutaxassis” nomi kiritiladi, oxirida esa auditoriyani tezkor ulashishga undovchi chaqiriq joylashtiriladi. Masalan, “rasmiy hujjat” ko‘rinishidagi skrinshot tarqatilib, unda muassasa rekvizitlari taqlid qilinadi, ammo matndagi stilistika va raqamlar mantiqan mos kelmaydi. Raqamlar nuqtayi nazaridan, tekshiruv amaliyotida dezinformatsion postlarning katta qismi vizual materiallar bilan kuchaytirilgani kuzatiladi, chunki rasm va video ishonch signalini beradi va qayta ishlash xarajatini kamaytiradi [3]. Ilmiy izoh shundan iboratki, semiotika va kommunikatsiya nazariyasi vizual belgilarni “haqiqat effekti”ni kuchaytiruvchi omil sifatida talqin qiladi, shu sababli tekshiruv protokoli vizual verifikatsiyani alohida bosqich sifatida kiritishi lozim [1]. Ijtimoiy tarmoqlarda dezinformatsiyani aniqlash usullari ko‘p qatlamli bo‘lib, birinchi qatlam manbani tekshirish va kontekstni qayta tiklashga qaratilgan usullar bilan ifodalanadi. Bu mexanizmga akkauntning yaratilgan sanasi, postlar ritmi, auditoriya bilan muloqot tili, oldingi kontentning mavzu barqarorligi kabi belgilar tahlil qilinadi va ular orqali manba autentikligi baholanadi. Masalan, qisqa vaqt ichida yuzlab post joylagan, lekin izohlar bilan muloqot qilmaydigan akkauntlar ko‘pincha avtomatlashtirilgan faoliyat belgisini beradi, buni bot tarmoqlari bilan bog‘lash mumkin. Statistik jihatdan, platformalarda bot-faollik ulushi mavzuga qarab keskin o‘zgaradi, ayniqsa trend mavzularida avtomatlashtirilgan ulashishlar ko‘payishi amaliy kuzatuvlarda qayd etiladi [4]. Ilmiy izoh sifatida tarmoq tahlili yondashuvi “markaziylik” va “klasterlash” ko‘rsatkichlari orqali sun’iy kuchaytirilgan tarqatish zanjirlarini aniqlash imkonini beradi, ya’ni bir xil kontentni bir vaqtda ulashayotgan tugunlar shubhali signal sifatida ko‘riladi [4].

Ikkinchi qatlam usullari kontentning ichki mantiqi va dalillash sifatini tekshirishga qaratilib, bu yerda faktcheking va manbalararo solishtirish asosiy o‘rin tutadi. Mexanizm shundan iboratki, da’vo tarkibiy qismlarga ajratiladi: kim, qachon, qayerda,



“KELAJAK TEKNOLOGIYALARI VA SUN’IY INTELLEKT”
nomli respublika ilmiy-amaliy masofaviy konferensiyasi
VOLUME-1, ISSUE-2, 2026

nima dedi yoki nima sodir bo‘ldi kabi savollar bilan tekshiruv savatchasi tuziladi va har bir bo‘lak mustaqil manba bilan tasdiqlanadi. Masalan, “falon sanada falon tashkilot yangi qoidani joriy etdi” degan da’vo bo‘lsa, tashkilotning rasmiy sayti, normativ hujjatlar bazasi va ishonchli OAV xabarlari o‘zaro solishtiriladi, sanalar mosligi va hujjat raqami tekshiriladi. Raqamli ko‘rsatkich sifatida amaliy faktcheking jarayonlarida rad etilgan da’volarning muhim qismi noto‘g‘ri sana, noto‘g‘ri joy yoki kontekstdan uzib olingan iqtibos tufayli yuzaga kelishi kuzatiladi, bu esa “mayda” detallar tekshiruvning asosiy nuqtasi ekanini bildiradi [1]. Ilmiy izoh nuqtayi nazaridan, manbashunoslik metodologiyasi birlamchi va ikkilamchi manbalar ierarxiasini belgilaydi, shuning uchun rasmiy hujjat yoki birlamchi bayonotga borib taqaladigan zanjir eng ishonchli hisoblanadi [5]. Uchinchi qatlam usullari metama’lumotlar va raqamli izlar orqali tekshirish bo‘lib, bu yondashuv sun’iy intellekt yordamida yaratilgan kontentni aniqlashda ayniqsa dolzarbdir. Mexanizmida rasm va videoning EXIF ma’lumotlari, fayl yaratish va tahrirlash izlari, siqish artefaktlari, soyalar geometriyasi, ovoz spektri va sinxronlik kabi belgilar tahlil qilinadi. Masalan, suratda quyosh soyasi yo‘nalishi voqea joyi va ko‘rsatilgan vaqt bilan mos kelmasa, yoki video kadrlarida lab harakati bilan audio uyg‘unlashmasa, bu montaj yoki sun’iy generatsiya ehtimolini oshiradi. Statistik jihatdan, so‘nggi yillarda “deepfake” sifatida tanilgan sintetik media holatlari ko‘payib borayotgani haqida xalqaro monitoringlar xabar beradi, bu esa tekshiruv vositalariga talabni oshirmoqda [2]. Ilmiy izoh shundan iboratki, generativ modellarning ishlashida ehtimollik taqsimotlari asosida tasvir sintezi yuz beradi va ayrim mayda tekstura yoki yoritish nomuvofiqliklari “model izi” sifatida qoladi, shu bois ekspertiza usullari kompyuter ko‘rish indikatorlariga tayanadi [2].

Tekshiruv jarayonini amaliyotga yaqinlashtirish uchun tezisda ijtimoiy tarmoq sharoitiga mos verifikatsiya protokoli taklif etiladi va u bosqichma-bosqich qaror qabul qilishni ta’minlaydi. Mexanizm sifatida “signal–dalil–xulosa” zanjiri qo‘llanadi: avval



“KELAJAK TEKNOLOGIYALARI VA SUN’IY INTELLEKT”
nomli respublika ilmiy-amaliy masofaviy konferensiyasi
VOLUME-1, ISSUE-2, 2026

shubha signallari qayd etiladi, so‘ng dalillar mustaqil manbalardan yig‘iladi, oxirida esa ehtimollik darajasiga asoslangan xulosa chiqariladi. Masalan, postdagi da’vo keskin, shoshilinch va emotsional bo‘lsa, birinchi signal sifatida belgilanadi; keyin rasm teskari qidiruvdan o‘tkaziladi, matndagi iqtibos asl manbada bor-yo‘qligi tekshiriladi, akkaunt tarmoq aloqalari ko‘rib chiqiladi. Raqamli amaliyotda bunday protokollar tekshiruv vaqtini qisqartirishi mumkin, chunki tartibga solingan ro‘yxat bo‘yicha harakat qilish kognitiv yuklamani kamaytiradi va xatolar ulushini pasaytiradi, faktchekerlar tajribasida standartlashtirish samaradorlikni oshirishi qayd etilgan [3]. Ilmiy izoh sifatida metodologik standartlash OAK talablari nuqtayi nazaridan ham muhim, chunki qayta tekshiriladigan, takrorlanadigan va natijasi izchil bo‘lgan usul ilmiylik mezonlariga yaqinlashadi [5]. Quyidagi jadval ijtimoiy tarmoqlarda uchraydigan dezinformatsiya turlarini aniqlash belgilarini solishtirma tahlil asosida umumlashtiradi va har bir tur uchun ustuvor tekshiruv manbalarini ko‘rsatadi. Mexanizmga ko‘ra, jadval “kontent shakli–tarqatish usuli–tekshiruv vositasi” mosligini beradi va foydalanuvchi qaysi usulni birinchi qo‘llashini tez tanlaydi. Masalan, manipulyativ sarlavha bilan berilgan havola uchun avvalo domen va sahifa tarixini tekshirish, rasmlari uchun teskari qidiruv va EXIF, statistik da’vo uchun birlamchi ma’lumotlar bazasiga murojaat qilish maqsadga muvofiq bo‘ladi. Raqam jihatidan, tekshiruv resurslarini to‘g‘ri taqsimlash bir postga sarflanadigan o‘rtacha vaqtni kamaytiradi va ko‘proq kontentni qamrab olish imkonini beradi, bu esa ta’limiy faktcheking laboratoriyalarida muhim samaradorlik ko‘rsatkichidir [4]. Ilmiy izoh sifatida, bunday tasniflash kommunikatsiya tadqiqotlarida tipologiya tuzish amaliyotiga mos keladi va empirik kuzatuvlarni tizimlashtirishga xizmat qiladi [1].

Jadval. Dezinformatsiya turlari va aniqlash indikatorlari



“KELAJAK TEKNOLOGIYALARI VA SUN’IY INTELLEKT”
nomli respublika ilmiy-amaliy masofaviy konferensiyasi
VOLUME-1, ISSUE-2, 2026

Turi: Soxta iqtibos. Asosiy indikator: manba ko‘rsatilmagan yoki noto‘g‘ri ko‘rsatilgan, stilistika mos emas. Ustuvor tekshiruv: birlamchi bayonot, rasmiy stenogramma, ishonchli OAV arxivi.

Turi: Kontekstdan uzib olingan video. Asosiy indikator: kesilgan kadrlar, oldingi-qo‘shimcha voqea yo‘q. Ustuvor tekshiruv: to‘liq video manbasi, voqea sanasi va joyi bo‘yicha geoverifikatsiya.

Turi: Sintetik tasvir (deepfake). Asosiy indikator: yuz mimikasi va yoritish nomuvofiqligi, artefaktlar. Ustuvor tekshiruv: metama’lumotlar, kadrma-kadr tahlil, audio spektr tekshiruvi.

Turi: Soxta statistika. Asosiy indikator: metodologiya berilmagan, raqamlar mantiqan mos kelmaydi. Ustuvor tekshiruv: rasmiy statistika bazalari, ilmiy hisobotlar, birlamchi datasetlar.

Turi: Bot orqali kuchaytirilgan trend. Asosiy indikator: bir xil matn, bir vaqtda ulashish, shubhali akkauntlar. Ustuvor tekshiruv: tarmoq tahlili, vaqt qatori, akkaunt tarixini tekshirish.

Sun’iy intellekt texnologiyalarining o‘zi ham dezinformatsiyani aniqlashda qo‘llaniladigan vosita ekanini hisobga olish zarur, chunki u matn va media tahlilida yordamchi analitik mexanizmlarni beradi. Mexanizm sifatida klassifikatsiya modellari shubhali postlarni risk darajasiga ko‘ra saralashi, klasterlash algoritmlari bir xil narrativlarni guruhlash, tabiiy tilni qayta ishlash esa manipulyativ uslub markerlarini topishi mumkin. Masalan, ko‘p takrorlanadigan emotsional birliklar, haddan tashqari umumlashtirish va “hamma biladi” kabi dalilsiz konstruktsiyalar avtomatik aniqlanib, tekshiruvga yo‘naltiriladi. Raqamlar nuqtayi nazaridan, katta hajmdagi oqimda inson faktchekeri hamma postni qo‘lda ko‘ra olmaydi, shu sababli saralash tizimi tekshiruv resursini prioritetlashga xizmat qiladi va samaradorlikni oshiradi [2]. Ilmiy izoh shundan iboratki, bunday avtomatlashtirishning cheklovi ham mavjud: model o‘rgatilgan



“KELAJAK TEXNOLOGIYALARI VA SUN’IY INTELLEKT”
nomli respublika ilmiy-amaliy masofaviy konferensiyasi
VOLUME-1, ISSUE-2, 2026

ma’lumotdagi og‘ishlar noto‘g‘ri ijobiy yoki noto‘g‘ri salbiy natijalarni keltirishi mumkin, shu bois inson nazorati va metodologik shaffoflik majburiy komponent bo‘lib qoladi [2]. Sun’iy intellekt davrida mediasavodxonlik ijtimoiy tarmoqlardagi axborotni faqat tushunish emas, balki tizimli tekshirish, dalilni qayta tiklash va raqamli izlarni tahlil qilish kompetensiyalarini ham o‘z ichiga oladigan kompleks ilmiy-amaliy soha sifatida namoyon bo‘ladi. Tezisda dezinformatsiyani aniqlashning uch qatlamli modeli asoslandi: manba va kontekstni tekshirish, kontentning ichki dalillash sifatini baholash, metama’lumotlar hamda sintetik media indikatorlari orqali verifikatsiya qilish. Taklif etilgan “signal–dalil–xulosa” protokoli platforma algoritmlari, foydalanuvchi xulqi va kontent shakli o‘rtasidagi bog‘liqlikni hisobga olgan holda tekshiruvni standartlashtirishga xizmat qiladi. Natijada mediasavodxonlik ta’limi uchun amaliy modullarni yangilash, OSINT ko‘nikmalarini kiritish va verifikatsiya madaniyatini shakllantirish zarurati ilmiy asoslangan holda umumlashtirildi.

Foydalanilgan adabiyotlar ro‘yxati

1. Wardle C., Derakhshan H. Information disorder: Toward an interdisciplinary framework for research and policymaking. Strasbourg: Council of Europe, 2017. 112 p.
2. Russell S., Norvig P. Artificial Intelligence: A Modern Approach. Boston: Pearson, 2021. 1152 p.
3. Silverman C. Verification handbook: An ultimate guideline on digital age sourcing for emergency coverage. Maastricht: European Journalism Centre, 2015. 124 p.
4. Vosoughi S., Roy D., Aral S. The spread of true and false news online. New York: AAAS, 2018. P. 1146–1151.
5. Qodirov A., Karimova N. Mediasavodxonlik asoslari va faktcheking amaliyoti. Toshkent: O‘zbekiston, 2022. 168 b.
6. Шейбл Д. Социальные сети и медиаманипуляции: методы распознавания. Москва: Аспект Пресс, 2020. 256 с.



Ways to improve the professional skills of a science teacher in the age of digital technologies

N. B. Utebaeva

*2st year, direction of education Applied mathematics Nukus State Pedagogical
Institute named after Ajiniyaz*

Annotation: This article examines the issues of improving the professional skill and digital competence of exact science teachers (mathematics, physics, computer science) in the context of modern digital technologies. The current problems in the education system are analyzed, and practical solutions are proposed for developing teachers' skills in using ICT tools, artificial intelligence, and interactive software. Recommendations have been developed to improve the system of enhancing the potential of pedagogical personnel.

Keywords: Digital technologies, exact sciences, professional skill, digital competence, methodology, artificial intelligence, professional development, interactive programs

Raqamli texnologiyalar asrida aniq fanlar o'qituvchisining kasbiy mahoratini oshirish yo'llari

N.B.Utebaeva -2-kurs, Amaliy-matematika ta'lim yo'nalishi

Ajiniyoz nomidagi Nukus davlat pedagogika instituti

Способы повышения профессиональных навыков учителя естественных наук в эпоху цифровых технологий.

Н.Б.Утебаева -2-курс, направление образования Прикладная математика

Нукусский государственный педагогический институт имени Ажинияза



“KELAJAK TEKNOLOGIYALARI VA SUN’IY INTELLEKT”
nomli respublika ilmiy-amaliy masofaviy konferensiyasi
VOLUME-1, ISSUE-2, 2026

Annotatsiya: Ushbu maqolada zamonaviy raqamli texnologiyalar sharoitida aniq fanlar (matematika, fizika, informatika) o‘qituvchilarining kasbiy mahorati va raqamli kompetentligini oshirish masalalari tadqiq etilgan. Ta’lim tizimidagi hozirgi muammolar tahlil qilinib, o‘qituvchilarning AKT vositalari, sun’iy intellekt va interaktiv dasturlardan foydalanish ko‘nikmalarini rivojlantirish bo‘yicha amaliy yechimlar taklif etilgan. Pedagog kadrlar salohiyatini oshirish tizimini takomillashtirish yuzasidan tavsiyalar ishlab chiqilgan.

Аннотация: В данной статье исследованы вопросы повышения профессионального мастерства и цифровой компетентности учителей точных наук (математика, физика, информатика) в условиях современных цифровых технологий. Проанализированы текущие проблемы в системе образования и предложены практические решения по развитию навыков использования учителями ИКТ-инструментов, искусственного интеллекта и интерактивных программ. Разработаны рекомендации по совершенствованию системы повышения потенциала педагогических кадров.

Kalit so‘zlar: Raqamli texnologiyalar, aniq fanlar, kasbiy mahorat, raqamli kompetentlik, metodika, sun’iy intellekt, malaka oshirish, interaktiv dasturlar

Ключевые слова: Цифровые технологии, точные науки, профессиональное мастерство, цифровая компетентность, методика, искусственный интеллект, повышение квалификации, интерактивные программы

XXI asr ta’lim tizimida tub burilishlar va texnologik transformatsiyalar davri bo‘lib qolmoqda. Bugungi kunda ta’lim faqatgina tayyor bilimlarni uzatish vositasi emas, balki o‘quvchilarda mustaqil fikrlash, tahlil qilish va muammolarni raqamli muhitda hal etish



"KELAJAK TEKNOLOGIYALARI VA SUN'IY INTELLEKT"
nomli respublika ilmiy-amaliy masofaviy konferensiyasi
VOLUME-1, ISSUE-2, 2026

ko'nikmalarini (21st-century skills) shakllantirish jarayonidir. Ayniqsa, matematika, fizika kabi aniq fanlarni o'qitishda an'anaviy "bo'r va doska" metodikasi o'quvchilarning diqqatini ushlab turish va fanga bo'lgan qiziqishini oshirish uchun yetarli bo'lmay qolyapti.

Aniq fanlarni o'qitish sifati to'g'ridan-to'g'ri pedagogning dars jarayoniga raqamli texnologiyalarni qanchalik professional darajada integratsiya qila olishiga, ya'ni uning raqamli kompetentligiga bog'liq. Shu bois, raqamli texnologiyalar asrida aniq fanlar o'qituvchisining kasbiy mahoratini muttasil oshirib borish mexanizmlarini ishlab chiqish dolzarb ijtimoiy-pedagogik zaruriyat hisoblanadi.

Hozirgi ta'lim amaliyotida raqamlashtirish jarayoni va o'qituvchilarning tayyorgarligi o'rtasida muayyan uzilishlar (nomutanosibliklar) ko'zga tashlanmoqda. Mavjud muammolarni quyidagicha guruhlash mumkin:

- ✓ Metodik bo'shliq: Ko'pgina o'qituvchilar kompyuter yoki sensorli doskalardan faqatgina taqdimot (PowerPoint) namoyish qilish uchun foydalanadilar. Vaholanki, aniq fanlarda mavhum tushunchalarni (masalan, funksiyalar grafigi, stereometrik shakllar, fizik jarayonlar) dinamik tarzda ko'rsatib beruvchi maxsus dasturlar (GeoGebra, Desmos, PhET simulyatsiyalari) dars samaradorligini bir necha barobar oshirishi isbotlangan.
- ✓ Raqamli fobiya va psixologik to'siqlar: Katta yoshli va tajribali o'qituvchilar orasida yangi raqamli platformalardan foydalanishga nisbatan ishonchsizlik yoki qo'rquv mavjud.



"KELAJAK TEKNOLOGIYALARI VA SUN'IY INTELLEKT"
nomli respublika ilmiy-amaliy masofaviy konferensiyasi
VOLUME-1, ISSUE-2, 2026

✓ Malaka oshirish tizimining shakliyligi: O'qituvchilarning malakasini oshirish kurslarida ko'pincha umumiy AKT tushunchalari beriladi, lekin aniq fan o'qituvchisining darsiga moslashtirilgan xususiy amaliy metodika yetishmaydi.

Tadqiqot metodologiyasi va natijalari

Aniq fanlar o'qituvchisining kasbiy mahoratini raqamli asr talablariga moslash uchun tizimli ravishda bir nechta innovatsion yo'llarni joriy etish lozim:

A. Matematik va vizual dasturiy ta'minotlarni o'zlashtirish

Matematika va fizika o'qituvchisi dars samaradorligini oshirish uchun quyidagi platformalar bilan ishlash malakasiga ega bo'lishi shart:

✓ GeoGebra: Geometriya, algebra va stereometriyani vizuallashtirish uchun eng mukammal vosita. O'qituvchi dynamic chizmalar orqali teoremlarni isbotlashni vizual namoyish qila olishi kerak.

✓ PhET Interactive Simulations: Fizik jarayonlar va laboratoriya ishlarini kompyuter formatida real vaqt rejimida modellashtirish imkonini beradi.

B. Sun'iy Intellekt (AI) resurslaridan foydalanish

Zamonaviy o'qituvchi o'z vaqtini tejash va darsni shaxsiylashtirish uchun sun'iy intellekt (masalan, ChatGPT, Gemini) yordamida:

✓ O'qituvchilarning bilim darajasiga moslashtirilgan tabaqalashtirilgan (differensial) testlar va misollar toplami tuzishi;

✓ Dars ishlanmalari va qiziqarli keyslarni (case-study) tezkor yaratishi mumkin.

D. "Uzluksiz professional rivojlanish" (Continuous Professional Development - CPD) modeli



"KELAJAK TEXNOLOGIYALARI VA SUN'IY INTELLEKT"
nomli respublika ilmiy-amaliy masofaviy konferensiyasi
VOLUME-1, ISSUE-2, 2026

O'qituvchi faqat 3 yoki 5 yilda bir marta malaka oshirish kursiga borishi yetarli emas. Professional mahoratni oshirish uchun mikro-ta'lim metodidan foydalanib, Coursera, Udey yoki milliy raqamli platformalardagi qisqa, maqsadli kurslarni doimiy o'qib borish tizimini yo'lga qo'yish zarur.

Xulosa qilib aytadigan bolsam, raqamli texnologiyalar asrida aniq fanlar o'qituvchisining mahorati uning qanchalik ko'p ma'lumot bilishida emas, balki o'sha ma'lumotlarni raqamli vositalar yordamida o'quvchiga qanchalik sodda, qiziqarli va kreativ tarzda yetkazib bera olishida namoyon bo'ladi.

Muammoni hal etish uchun quyidagi amaliy qadamlarni amalga oshirish taklif etiladi:

- ✓ Pedagogika universitetlarida tahsil olayotgan bo'lajak aniq fanlar o'qituvchilarining o'quv dasturlariga "Aniq fanlarni o'qitishda raqamli texnologiyalar" nomli maxsus amaliy fanlarni kiritish.
- ✓ Maktablarda o'qituvchilar uchun haftalik raqamli master-klasslar va o'zaro tajriba almashish ("ustoz-shogird" va professional jamoalar) tizimini tashkil etish.
- ✓ O'qituvchilar kasbiy mahoratini baholashda ularning darsda AKT va interaktiv simulyatsiyalardan qanchalik unumli foydalanganliklarini asosiy mezonlardan biri sifatida belgilash.

Foydalanilgan adabiyotlar (References)

1. O'zbekiston Respublikasi Prezidentining 2020-yil 6-noyabrdagi "Ta'lim-tarbiya tizimini yanada takomillashtirishga oid qo'shimcha chora-tadbirlar to'g'risida"gi PQ-4884-sonli Qarori.



“KELAJAK TEXNOLOGIYALARI VA SUN’IY INTELLEKT”
nomli respublika ilmiy-amaliy masofaviy konferensiyasi
VOLUME-1, ISSUE-2, 2026

2. Azizxo‘jayeva N.N. Pedagogik texnologiya va pedagogik mahorat. – T.: TDPU, 2006. – 160 b.
3. Hohenwarter, M., & Fuchs, K. (2004). *Combination of dynamic geometry, algebra and calculus in the software system GeoGebra*. Computer Algebra Systems and Dynamic Geometry Software in Mathematics Education.
4. Mishra, P., & Koehler, M. J. (2006). *Technological pedagogical content knowledge: A framework for teacher knowledge*. Teachers College Record, 108(6), 1017-1054.
5. Robert, I. V. (2014). *Modern informatization of education: didactic problems and perspectives*. Moscow: IIO RAO.



ANALYSIS OF NMR RESULTS FOR THE ALKALOID SKIMMIANINE

Jalolov Iqboljon Jamolovich

Dolimova Umidaxon Arabjon qizi

Dolimov Xayotjon Xakimjon o'g'li

1.Fergana State University 2.Fergana Medical Institute Public Health

ABSTRACT

This work develops a research methodology based on modern NMR spectroscopy techniques for the complete structural characterization of Skimmianine, a furoquinoline alkaloid isolated from plants of the Rutaceae family. Experiments were conducted in a DMSO-d₆ + CCl₄ solvent mixture at a frequency of 600 MHz. The ¹H and ¹³C NMR chemical shifts (δ , ppm) of the compound, as well as long-range proton-carbon correlations from the HMBC (Heteronuclear Multiple Bond Correlation) spectrum, were analyzed in detail. The HMBC experiment unambiguously determined the connectivity of the furan ring (H-2, H-3) to the quinoline skeleton, the position of the ortho-substituted protons (H-5, H-6) on the benzene ring, and most importantly, the precise positions of the three methoxy groups (4-OCH₃, 7-OCH₃, 8-OCH₃). For example, the HMBC correlations demonstrated 4-OCH₃ (4.44 ppm) with C-4 (156.34 ppm), 7-OCH₃ (3.98 ppm) with C-7 (151.49 ppm), and 8-OCH₃ (3.96 ppm) with C-8 (141.51 ppm).

The presented methodology demonstrates the advantage of combining 1D NMR with 2D NMR (HSQC, HMBC) methods for elucidating the structure of complex natural compounds. This approach ensures the complete and reliable structural assignment of polymethoxylated furoquinoline alkaloids such as Skimmianine and also allows for the correction of previous misassignments found in the literature.

Keywords: Skimmianine, furoquinoline alkaloid, ¹H NMR, ¹³C NMR, HMBC, HSQC, structural analysis, methoxy group position determination, 2D NMR spectroscopy.



SKIMMIANIN ALKALOIDINING YaMR NATIJALARI TAHLILI.

ANNOTATSIYA. Ushbu ishda Rutaceae oilasiga mansub o‘simliklardan ajratib olinadigan furoxinololin alkaloidi — Skimmianin ning to‘liq strukturaviy karakterizatsiyasi uchun zamonaviy NMR spektroskopiya usullari asosida tadqiqot metodologiyasi ishlab chiqilgan. Tajribalar DMSO-d₆ + CCl₄ erituvchilar aralashmasida, 600 MGts chastotada o‘tkazilgan. Birikmaning ¹H va ¹³C NMR kimyoviy siljishlari (δ, ppm), shuningdek, HMBC (Heteronuclear Multiple Bond Correlation) spektridagi uzoq masofali proton-uglerod korrelyatsiyalari batafsil tahlil qilingan. HMBC tajribasi natijasida furan halqasining (H-2, H-3) xinolin skeletiga ulanish tartibi, benzol halqasidagi orto-orin almashgan protonlarning (H-5, H-6) joylashuvi va eng muhimi, uchta metoksiguruhning (4-OCH₃, 7-OCH₃, 8-OCH₃) aniq o‘rni bir ma’noda aniqlangan. Masalan, 4-OCH₃ (4.44 ppm) C-4 (156.34 ppm) bilan, 7-OCH₃ (3.98 ppm) C-7 (151.49 ppm) bilan va 8-OCH₃ (3.96 ppm) C-8 (141.51 ppm) bilan HMBC korrelyatsiyasi namoyish etgan.

Taqdim etilgan metodologiya 1D NMR bilan bir qatorda 2D NMR (HSQC, HMBC) usullarining murakkab tabiiy birikmalar strukturasi aniqlashdagi ustunligini ko‘rsatadi. Ushbu yondashuv Skimmianin kabi polimetoksillangan furoxinololin alkaloidlarining to‘liq va ishonchli strukturaviy tayinlanishini ta’minlaydi, shuningdek, ilgari adabiyotlarda uchraydigan noto‘g‘ri tayinlashlarni tuzatishga imkon yaratadi.

Kalit so‘zlar: Skimmianin, furoxinololin alkaloidi, ¹H NMR, ¹³C NMR, HMBC, HSQC, strukturaviy tahlil, metoksiguruhlarning o‘rnini aniqlash, 2D NMR spektroskopiyasi.

KIRISH. Skimmianin (4,7,8-trimetoksifuro[2,3-b]xinolin) — bu asosan Rutaceae (sadoqatdoshlar) oilasiga mansub o‘simliklardan ajratib olingan tabiiy furoxinololin alkaloidi. Ushbu birikma o‘zining xilma-xil biologik faolligi, jumladan, sitotoksik, antikanser va antioksidant xususiyatlari bilan ilmiy tadqiqotlarda katta



“KELAJAK TEKNOLOGIYALARI VA SUN’IY INTELLEKT”
nomli respublika ilmiy-amaliy masofaviy konferensiyasi
VOLUME-1, ISSUE-2, 2026

qiziqish uyg‘otadi. Dastlabki tadqiqotlarda uning strukturasi an’anaviy usullar (UV, IR, 1D NMR) yordamida aniqlangan bo‘lsa-da, ba’zi adabiyotlarda uglerod va vodorod atomlarining signallari noto‘g‘ri tayinlangan holatlar mavjud.

1990-yilda Jackson va boshqalar tomonidan olib borilgan ikki o‘lchovli (2D) NMR spektroskopiyasi (HETCOR va Long-range HETCOR, HMBC ning oldingi versiyasi) tadqiqotlari Skimmianin kabi murakkab alkaloidlarning to‘liq va aniq strukturaviy tayinlanishida inqilob qildi. Ushbu usullar yordamida proton va uglerod atomlari orasidagi qisqa va uzoq masofali (2-3 bog‘) korrelyatsiyalarni aniqlash orqali molekulaning to‘liq skeletini qayta qurish mumkin. Zamonaviy tadqiqotlarda esa, HMBC (Heteronuclear Multiple Bond Correlation) va HSQC (Heteronuclear Single Quantum Coherence) kabi 2D NMR texnikalari standart usulga aylangan. Bizning tadqiqotimizda aynan shu ilg‘or usullardan foydalanib, DMSO-d₆+CCl₄ erituvchilar aralashmasida va 600 MGts chastotada olingan ma’lumotlar asosida Skimmianin strukturasi batafsil tahlil qilamiz.

TADQIQOT METODI. Tadqiqot obyekti sifatida tozalangan Skimmianin birikmasi ishlatiladi. Birikma Rutaceae oilasiga mansub o‘simliklardan (masalan, *Toddalia asiatica* yoki *Araliopsis soyauxii*) standart fitokimyoviy usullar — ekstraksiya (maseratsiya), turli xil xromatografik usullar (ustun xromatografiyasi, radial xromatografiyasi) yordamida ajratib olinadi va tozalanadi. Tayyorligi TLC (yupqa qatlamli xromatografiya) orqali tekshiriladi. So‘ngra, namunaning 10-20 mg miqdori DMSO-d₆ (deyterlangan dimetil sulfoksid) va CCl₄ (uglerod tetraklorid) aralashmasida (ma’lum nisbatda) eritiladi va 5 mm li NMR kyuvetasiga quyiladi.

Barcha NMR tajribalari 600 MGts ish chastotasiga ega zamonaviy spektrometrda (masalan, Agilent VNMRS 600) xona haroratida o‘tkaziladi. Kimyoviy siljishlar (δ , ppm) tetrametilsilan (TMS) yoki erituvchining qoldiq signaliga nisbatan o‘lchanadi. Quyidagi tajribalar o‘tkaziladi:



“KELAJAK TEKNOLOGIYALARI VA SUN’IY INTELLEKT”
nomli respublika ilmiy-amaliy masofaviy konferensiyasi
VOLUME-1, ISSUE-2, 2026

^1H NMR: Protonlarning kimyoviy siljishlarini, ularning multiplitetligini (dublet, singlet va h.k.) va o‘zaro ta’sir qilish doimiylarini (J, Gts) aniqlash uchun.

^{13}C NMR va DEPT-135: Uglerod atomlari sonini va ularning turini (CH_3 , CH_2 , CH va kvaterner C) aniqlash.

HSQC (^1H - ^{13}C Heteronuclear Single Quantum Coherence): Bir xil uglerod atomiga bog‘langan proton va uglerod juftligini to‘g‘ridan-to‘g‘ri (^1JCH) bog‘lanish orqali aniqlash. Bu tajriba vodorod va unga bevosita bog‘liq bo‘lgan uglerod signalini moslashtirish imkonini beradi.

HMBC (^1H - ^{13}C Heteronuclear Multiple Bond Correlation): Proton va undan 2-3 bog‘ uzoqlikda joylashgan uglerod atomlari orasidagi korrelyatsiyani aniqlash. Bu molekuladagi atomlarning bog‘lanish ketma-ketligini va qo‘shnilik munosabatlarini, ayniqsa, bir-biriga bevosita bog‘lanmagan kvaterner uglerodlar va protonlar orasidagi aloqani o‘rnatishda muhim rol o‘ynaydi.

Skimmianin birikmasining ^1H va ^{13}C YaMR kimyoviy siljishi (DMSO- d_6 + CCl_4 , d, ppm, 600 MGts) va HMBC tajriba ma’lumotlari

Atom C	δ_C	δ_H (J/Gts)	HMBC (H→C)
2	142.85	7.76, d (2.8)	3, 3a, 9a
3	104.71	7.27, d (2.8)	3a, 2, 9a
3a	101.47		
4	156.34		
4a	114.20		
5	117.44	7.92, d (9.3)	4, 7, 8a
6	111.99	7.23, d (9.3)	4a, 7, 8
7	151.49		
8	141.51		

8a	140.77		
9a	163.50		
4-OCH ₃	58.76	4.44, c	4
7-OCH ₃	56.21	3.98, c	7
8-OCH ₃	60.38	3.96, c	8

NATIJAR TAXLILI. Skimmianin – furo[2,3-b]xinolina skeletiga ega bo‘lgan tabiiy alkaloid bo‘lib, asosan *Skimmia*, *Dictamnus*, *Zanthoxylum* kabi o‘simliklar tarkibida uchraydi. Ushbu birikmaning tuzilishini aniqlashda zamonaviy NMR spektroskopiyasi, xususan ¹H NMR, ¹³C NMR va HMBC usullari keng qo‘llaniladi. Quyida DMSO-d₆ + CCl₄ erituvchilar aralashmasida, 600 MHz chastotada olingan spektral ma’lumotlar asosida batafsil tahlil keltirilgan.

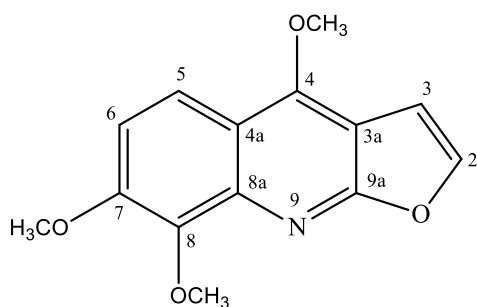

Chemical Formula: C₁₄H₁₃NO₄

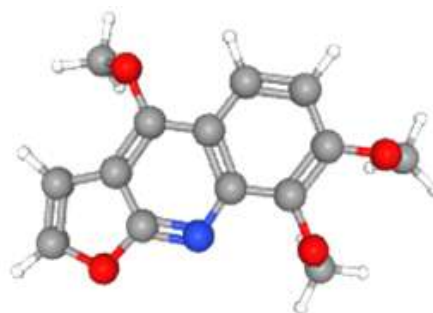

Skimmianin yoki sistematik nomi 4,7,8-trimetoksifuro[2,3-b]xinolin

¹³C NMR kimyoviy siljishlarining tahlili: C2: 142.85 ppm – Furan halqasining kislorodga tutash uglerodi (O–CH=), elektron tortuvchi ta’sir tufayli past maydonda, C3: 104.71 ppm – Furan halqasidagi =CH– guruhi, C2 va C3a orasida, nisbatan yuqori maydonda, C3a: 101.47 ppm – Furan va xinolin tutashgan kvaterner uglerod; juda yuqori maydon aromatik halqalar orasidagi bog‘lanish xarakteristikasi, C4: 156.34 ppm – Xinolinning 4-pozitsiyasi, OCH₃ birikkan uglerod; kislorod ta’sirida kuchli past maydon, C4a: 114.20 ppm – Xinolinning C4 va C5 orasidagi kvaterner aromatik uglerod, C5: 117.44 ppm – Aromatik CH (H5 bilan bog‘langan, J=9.3 Hz), C6: 111.99



“KELAJAK TEKNOLOGIYALARI VA SUN’IY INTELLEKT”
nomli respublika ilmiy-amaliy masofaviy konferensiyasi
VOLUME-1, ISSUE-2, 2026

ppm – Aromatik CH (H6 bilan bog‘langan, $J=9.3$ Hz), C7: 151.49 ppm – Aromatik C7 – OCH₃ birikkan, kuchli past maydon, C8: 141.51 ppm – C8 – OCH₃ birikkan, past maydon, C8a: 140.77 ppm – Xinolinning C8 va azot orasidagi kvaterner uglerod, C9a: 163.50 ppm – Furan va xinolin tutashgan ikkinchi kvaterner uglerod; kislorod va azot ta’sirida eng past maydon, 4-OCH₃: 58.76 ppm – Metoksi, kislorodga tutash, normal diapazon, 7-OCH₃: 56.21 ppm – Metoksi, 8-OCH₃: 60.38 ppm – Metoksi; 8-pozitsiyadagi sterik to‘siq tufayli biroz pastroq maydonga siljigan, C3a (101.47) va C9a (163.50) orasidagi katta farq furan halqasining yo‘nalishini (furo[2,3-b]xinolina ekanligini) tasdiqlaydi. Uchta metoksi guruhining δC farqlari ularning turli aromatik muhitda joylashganini ko‘rsatadi. ¹H NMR kimyoviy siljishlari va spin-spin konstantalarining tahlili. H2: 7.76 ppm, dublet, $J=2.8$ Hz – Furan halqasidagi H2; H3 bilan meta-bog‘lanish (furanga xos kichik konstanta), H3: 7.27 ppm, dublet, $J=2.8$ Hz – Furan halqasidagi H3; H2 bilan bir xil J – ular bir-biriga juftlashgan, H5: 7.92 ppm, dublet, $J=9.3$ Hz – Xinolinning A halqasidagi H5; H6 bilan orto bog‘lanish (tipik aromatik orto J), H6: 7.23 ppm, dublet, $J=9.3$ Hz – Xinolinning H6; H5 bilan orto bog‘lanish; 7-OCH₃ elektron beruvchi ta’sir tufayli nisbatan yuqori maydonda, 4-OCH₃: 4.44 ppm, singlet – 4-pozitsiyadagi metoksi; qo‘shni proton yo‘q, 7-OCH₃: 3.98 ppm, singlet – 7-OCH₃, aromatik metoksi, 8-OCH₃: 3.96 ppm, singlet – 8-OCH₃, aromatik metoksi, H5 va H6 o‘rtasidagi $J = 9.3$ Hz – orto bog‘lanishning aniq belgisi, H2 va H3 o‘rtasidagi $J = 2.8$ Hz – furan halqasiga xos bo‘lib, aromatik halqadagi katta konstantalardan farq qiladi. Bu furan-xinolina tuzilmasini qo‘llab-quvvatlaydi. Eng past maydonda H5 (7.92 ppm) – C4 metoksi va C7 metoksi ta’sirida. Eng yuqori maydonda H6 (7.23 ppm) – C7 va C8 metoksilari orasida ekranlangan.

HMBC (¹H–¹³C Heteronuclear Multiple Bond Correlation) tahlili. HMBC 2–3 bog‘ orqali proton va uglerod o‘rtasidagi korrelyatsiyalarni ko‘rsatadi. Quyida har bir proton uchun kuzatilgan muhim korrelyatsiyalar keltirilgan. H2 (7.76 ppm, d, $J=2.8$ Hz)



“KELAJAK TEKNOLOGIYALARI VA SUN’IY INTELLEKT”
nomli respublika ilmiy-amaliy masofaviy konferensiyasi
VOLUME-1, ISSUE-2, 2026

bilan HMBC korrelyatsiyalari, C3 (104.71 ppm) – 3J bog‘lanish (H2–C2–C3 orqali), C3a (101.47 ppm) – 3J bog‘lanish (H2–C2–C3a orqali) – furan halqasini xinolinga biriktiradi. C9a (163.50 ppm) – 2J yoki 3J bog‘lanish – eng muhim korrelyatsiya: H2 ning C9a bilan korrelyatsiyasi furan halqasining 2-pozitsiyasini xinolinning 9a uglerodi bilan bog‘laydi, bu tuzilmaning asosiy dalili hisoblanadi. H3 (7.27 ppm, d, $J=2.8$ Hz) bilan HMBC korrelyatsiyalari. C2 (142.85 ppm) – 3J bog‘lanish (H3–C3–C2 orqali), C3a (101.47 ppm) – 2J bog‘lanish, C9a (163.50 ppm) – 3J bog‘lanish (H3–C3–C3a–C9a orqali) H5 (7.92 ppm, d, $J=9.3$ Hz) bilan HMBC korrelyatsiyalari. C4 (156.34 ppm) – 3J bog‘lanish (H5–C5–C4a–C4 orqali) – 4-metoksi bog‘lanish joyini tasdiqlaydi, C8a (140.77 ppm) – 3J bog‘lanish (H5–C5–C4a–C8a orqali), C4a (114.20 ppm) – 3J bog‘lanish. H6 (7.23 ppm, d, $J=9.3$ Hz) bilan HMBC korrelyatsiyalari. C4a (114.20 ppm) – 3J bog‘lanish (H6–C6–C5–C4a orqali), C7 (151.49 ppm) – 3J bog‘lanish (H6–C6–C7 orqali) – juda muhim: 7-OCH₃ ning C7 ga birikkanligini isbotlaydi, C8 (141.51 ppm) – 3J bog‘lanish (H6–C6–C7–C8 orqali) – 8-OCH₃ ning C8 ga birikkanligini tasdiqlaydi. Metoksi guruhlarining HMBC korrelyatsiyalari. 4-OCH₃ (4.44 ppm, singlet) – C4 (156.34 ppm) ga 2J bog‘lanish orqali korrelyatsiya beradi (o‘z uglerodiga), 7-OCH₃ (3.98 ppm, singlet) – C7 (151.49 ppm) ga 2J bog‘lanish orqali korrelyatsiya beradi, 8-OCH₃ (3.96 ppm, singlet) – C8 (141.51 ppm) ga 2J bog‘lanish orqali korrelyatsiya beradi

H2 (7.76 ppm) → C3a (101.47) va C9a (163.50) bilan korrelyatsiya beradi. Bu furan halqasining xinolinga 2,3-b usulida anellanganligini isbotlaydi. H3 (7.27 ppm) → C2 (142.85) va C3a (101.47) bilan korrelyatsiya beradi. Bu furan halqasini to‘ldiradi. H5 (7.92 ppm) → C4 (156.34) va C8a (140.77) bilan korrelyatsiya beradi. Bu 4-OCH₃ ning joyini va A halqasining pozitsiyalarini belgilaydi. H6 (7.23 ppm) → C7 (151.49) va C8 (141.51) bilan korrelyatsiya beradi. Bu 7 va 8-OCH₃ larning aniq joylashuvini belgilaydi. 4-OCH₃ (4.44 ppm) → C4 (156.34) ga korrelyatsiya beradi – metoksi



“KELAJAK TEKNOLOGIYALARI VA SUN’IY INTELLEKT”
nomli respublika ilmiy-amaliy masofaviy konferensiyasi
VOLUME-1, ISSUE-2, 2026

bog‘lanishini tasdiqlaydi. 7-OCH₃ (3.98 ppm) → C7 (151.49) ga korrelyatsiya beradi – metoksi bog‘lanishini tasdiqlaydi. 8-OCH₃ (3.96 ppm) → C8 (141.51) ga korrelyatsiya beradi – metoksi bog‘lanishini tasdiqlaydi.

XULOSA

Ushbu ¹H NMR, ¹³C NMR va HMBC spektral tahlil asosida quyidagi xulosalar chiqariladi: Skimmianin – furo[2,3-b]xinolina skeletiga ega birikma ekanligi tasdiqlandi. Furan halqasining 2 va 3 pozitsiyalaridagi protonlar o‘zaro J = 2.8 Hz orqali bog‘langan, bu furan halqasiga xos kichik konstanta hisoblanadi. Xinolinning A halqasi 5,6,7,8 pozitsiyalarida almashtirilgan: 5 va 6 pozitsiyalarida protonlar mavjud (J = 9.3 Hz – orto bog‘lanish), 7 va 8 pozitsiyalarida metoksi guruhlari birikkan. 4-pozitsiyada metoksi guruhi (δC 156.34, δH 4.44) joylashgan. Uning HMBC korrelyatsiyasi C4 bilan birikkanligini ko‘rsatadi. 7-OCH₃ (δC 56.21, δH 3.98) va 8-OCH₃ (δC 60.38, δH 3.96) larning δC farqi hamda ularning H6 protoni bilan HMBC korrelyatsiyalari ularning o‘rnini aniq belgilaydi. C9a ning juda past maydonda (163.50 ppm) bo‘lishi – bu uglerodning furan va xinolinning birlashmasida, azot va kislorod ta’sirida ekanligini ko‘rsatadi. HMBC tahlili birikmaning furo[2,3-b]xinolina tuzilmasini boshqa mumkin bo‘lgan izomerlardan (masalan, furo[2,3-c]xinolina yoki furo[3,2-c]xinolina) farqlashda hal qiluvchi ahamiyatga ega. Ayniqsa H2 ning C9a va C3a bilan, H5 ning C4 va C8a bilan, H6 ning C7 va C8 bilan korrelyatsiyasi bir qiymatli tasdiqlaydi.

Adabiyotlar ro‘yxati

1. Ninh The Son. Skimmianine: Natural Occurrence, Biosynthesis, Synthesis, Pharmacology and Pharmacokinetics // Medicinal Chemistry. – 2023. – Vol. 19, No. 6. – P. 556-569.
2. Mora S., Castro V., Poveda L., Chavarría M., Murillo R. Chemical constituents from *Zanthoxylum setulosum* (Rutaceae) // Boletín Latinoamericano y del



“KELAJAK TEKNOLOGIYALARI VA SUN’IY INTELLEKT”
nomli respublika ilmiy-amaliy masofaviy konferensiyasi
VOLUME-1, ISSUE-2, 2026

- Caribe de Plantas Medicinales y Aromáticas. – 2011. – Vol. 10, No. 2. – P. 155-158.
3. Parhoodeh P., Rahmani M., Hashim N.M., Sukari M.A., Ee G.C.L. Alkaloid Constituents of *Haplophyllum laeviusculum* (Rutaceae) // Sains Malaysiana. – 2012. – Vol. 41, No. 1. – P. 47-52.
 4. Mashimbye M.J., Maumela M.C., Raphulu M.C. The X-Ray structure and the ¹³C NMR data of chelerythrine acetate from *Zanthoxylum davyi* // Nigerian Journal of Natural Products and Medicine. – 2000. – Vol. 4. – P. 57-61.
 5. Corrêa D.B., et al. Structural confirmation of dihydrocinnamic acids from *Adiscanthus fusciflorus* by ¹³C NMR // Phytochemistry. – 1980. – Vol. 19. – P. 659-662.
 6. Adamska-Szewczyk A., Glowniak K., Baj T. Furochinoline alkaloids in plants from Rutaceae family – a review // Current Issues in Pharmacy and Medical Sciences. – 2016. – Vol. 29, No. 1. – P. 33-38.
 7. Matsuo M., Yamazaki M., Kasida Y. Biosynthesis of skimmianine // Biochemical and Biophysical Research Communications. – 1966. – Vol. 23, No. 5. – P. 679-682.
 8. Murugan N., Srinivasan R., Murugan A., Kim M., Natarajan D. *Glycosmis pentaphylla* (Rutaceae): A natural candidate for the isolation of potential bioactive arborine and skimmianine compounds for controlling multidrug-resistant *Staphylococcus aureus* // Frontiers in Public Health. – 2020. – Vol. 8. – P. 176.
 9. BioCrick. Skimmianin: CAS 83-95-4 – High Purity for Research Use. – URL: <https://biocrick.com> (murojaat sanasi: 21.05.2026).
 10. YM-SW. Skimmianine – Product Specification. – URL: <http://www.ym-sw.com> (murojaat sanasi: 21.05.2026).



Household Consumption, Imports, and Investment Activity in Uzbekistan

Murodil Isroiljonov Qosimjon o‘g‘li

Undergraduate Student, Faculty of Economics Tashkent State University of Economics

ORCID: <https://orcid.org/0009-0009-5149-1341>

Email: murodil.isroiljonov06@gmail.com

Abstract

This thesis examines the relationship between household consumption expenditure, imports of goods and services, and gross capital formation in Uzbekistan during 2016Q1–2025Q4. The study applies the Autoregressive Distributed Lag (ARDL) approach using quarterly macroeconomic data to estimate the long-run relationship among the variables. The empirical findings indicate that household consumption expenditure and imports positively and significantly affect gross capital formation in the long run. The results suggest that stronger domestic demand and productive imports contribute positively to investment activity and capital accumulation in Uzbekistan. The study highlights the importance of sustainable domestic demand and investment-supporting trade activity for long-run economic development.

Keywords

household consumption expenditure, imports, gross capital formation, ARDL, investment activity, Uzbekistan.

Introduction. Gross capital formation is an important component of economic growth and productive expansion in developing economies. Household consumption expenditure may stimulate investment activity through stronger domestic demand, while imports of goods and services may support production and modernization through access to machinery, equipment, and intermediate inputs. In recent years, economic reforms and trade liberalization in Uzbekistan have increased the importance of domestic demand and external trade activity in supporting investment processes.





“KELAJAK TEXNOLOGIYALARI VA SUN’IY INTELLEKT”
nomli respublika ilmiy-amaliy masofaviy konferensiyasi
VOLUME-1, ISSUE-2, 2026

Therefore, this thesis examines the relationship between household consumption expenditure, imports, and gross capital formation in Uzbekistan during 2016Q1–2025Q4 using the ARDL econometric approach.

Data and Methodology. The study uses quarterly macroeconomic data obtained from the Statistics Agency under the President of the Republic of Uzbekistan covering the period 2016Q1–2025Q4. Gross capital formation was selected as the dependent variable, while household consumption expenditure and imports of goods and services were included as explanatory variables. Since the official quarterly indicators were reported in cumulative form, the data were converted into non-cumulative quarterly values before estimation. All variables were transformed into natural logarithmic form to improve model properties and obtain elasticity interpretations. The relationship among the variables was estimated using the ARDL framework:

$$\ln(Y_t) = \beta_0 + \beta_1 \ln(X1_t) + \beta_2 \ln(X2_t) + \varepsilon_t$$

where Y denotes gross capital formation, X1 represents household consumption expenditure, and X2 indicates imports of goods and services. The ARDL methodology allows estimation of both long-run equilibrium relationships and short-run dynamics among macroeconomic variables. Augmented Dickey–Fuller unit-root tests confirmed that all variables were integrated of order one, I(1), supporting the suitability of the ARDL approach for estimation.

Results and Discussion. The estimation results demonstrate that household consumption expenditure and imports of goods and services positively and significantly affect gross capital formation in Uzbekistan. The estimated long-run coefficient for household consumption expenditure equals 0.619, indicating that a 1% increase in household consumption expenditure contributes to approximately 0.62% growth in gross capital formation. This finding suggests that stronger domestic demand encourages firms to expand productive capacity and increase investment activity.



“KELAJAK TEKNOLOGIYALARI VA SUN’IY INTELLEKT”
nomli respublika ilmiy-amaliy masofaviy konferensiyasi
VOLUME-1, ISSUE-2, 2026

Imports of goods and services also demonstrate a positive and statistically significant relationship with gross capital formation. The estimated coefficient for imports equals 0.462, implying that a 1% increase in imports contributes to approximately 0.46% growth in gross capital formation. The positive import effect may reflect the importance of imported machinery, industrial equipment, and intermediate goods in supporting productive expansion and economic modernization processes. The estimated error-correction coefficient equals -0.995 and remains statistically significant, confirming the existence of a stable long-run equilibrium relationship among the variables. The magnitude of the adjustment coefficient indicates rapid convergence toward long-run equilibrium following short-run macroeconomic deviations. Overall, the findings suggest that household consumption expenditure and productive imports represent important determinants of investment activity and capital accumulation in Uzbekistan.

Conclusion. This thesis examined the relationship between household consumption expenditure, imports of goods and services, and gross capital formation in Uzbekistan during 2016Q1–2025Q4 using the ARDL econometric approach. The findings indicate that both household consumption expenditure and imports positively contribute to gross capital formation in the long run. The results suggest that strengthening domestic demand, supporting productive imports, and improving investment conditions may contribute positively to sustainable economic development and capital accumulation in Uzbekistan.

References

1. Mankiw, N. G. (2021). *Macroeconomics (11th ed.)*. Worth Publishers.
2. Pesaran, M. H., Shin, Y., & Smith, R. J. (2001). *Bounds testing approaches to the analysis of level relationships*. *Journal of Applied Econometrics*.
3. *Statistics Agency of Uzbekistan* siat.stat.uz



Development of an Automated Information System for Grocery Stores Based on a Three-Tier Architecture

Nasibonov Muhammadali Dilshodbek o‘g‘li

4th-year Student, Information Systems and Technologies Program

Andijan State Technical Institute

Scientific Supervisor: Zulfixarov Ilxom Maxmudovich Tel: +998 91 288 33 38

Abstract. This article presents an information system developed for the automation of grocery stores based on a three-tier architecture using PHP 8.2 and MySQL. The system provides specialized interfaces for five different user roles, implements a Role-Based Access Control (RBAC) security model, and supports ACID transactions to ensure data integrity and reliability. The solution is specifically adapted to the conditions of Uzbekistan and is capable of operating in both cloud-based and offline environments. The proposed system aims to improve business process efficiency, data management, and transaction security in retail grocery operations.

Keywords: automated system, three-tier architecture, PHP, MySQL, RBAC, ACID transaction, POS terminal.

OZIQ-OVQAT DO‘KONLARI UCHUN UCH QATLAMLI ARXITEKTURA ASOSIDA AVTOMATLASHTIRILGAN AXBOROT TIZIMINI ISHLAB CHIQISH

**Andijon Davlat Texnika Instituti Axborot tizimlari va texnologiyalari
yo‘nalishi 4-kurs talabasi Nasibonov Muhammadali Dilshodbek o‘g‘li**

Ilmiy rahbar: Zulfixarov Ilxom Maxmudovich Tel: +998 91 288 33 38

Maqolada oziq-ovqat do‘konlarini avtomatlashtirish uchun ishlab chiqilgan, PHP 8.2 va MySQL asosidagi uch qatlamli arxitekturaga ega axborot tizimi taqdim etilgan. Tizim besh xil foydalanuvchi roli uchun maxsus interfeyslar, RBAC xavfsizlik modeli va



“KELAJAK TEKNOLOGIYALARI VA SUN’IY INTELLEKT”
nomli respublika ilmiy-amaliy masofaviy konferensiyasi
VOLUME-1, ISSUE-2, 2026

ACID tranzaksiyalarni qo‘llaydi. Ishlanma O‘zbekiston sharoitlariga mahsus moslashtirilgan bo‘lib, ham bulutli ham oflayn rejimlarda ishlash imkoniyatiga ega.

Kalit so‘zlar: *avtomatlashtirilgan tizim, uch qatlamli arxitektura, PHP, MySQL, RBAC, ACID tranzaksiya, POS terminal.*

Kirish. O‘zbekiston Respublikasida raqamli iqtisodiyotni rivojlantirish strategiyasiga muvofiq kichik biznes sektorida axborot texnologiyalarini joriy etish dolzarb vazifa hisoblanadi. Statistika qo‘mitasi ma’lumotlariga ko‘ra, respublikada 287 mingdan ortiq oziq-ovqat do‘konlari faoliyat yuritmoqda, ammo ulardan faqatgina 8,3% ga yaqini avtomatlashtirilgan savdoni boshqarish tizimlaridan foydalanmoqda. Bu ko‘rsatkich rivojlangan davlatlardagi 70-85% darajadagi avtomatlashtirish ko‘rsatkichlaridan sezilarli orqada qolayotganligini ko‘rsatadi.

Mavjud xalqaro yechimlar (1C, Odoo, Poster POS) O‘zbekiston bozoriga to‘liq moslashtirilmagan: ular mahalliy soliq qonunchiligini, milliy to‘lov tizimlarini va o‘zbek tilini to‘liq qo‘llab-quvvatlamaydi. Bundan tashqari, ushbu yechimlarning yillik litsenziya narxi kichik biznes uchun moliyaviy yuk tug‘diradi. Mazkur tadqiqotning maqsadi — O‘zbekiston sharoitlariga moslashtirilgan, ochiq kodli, samarali va ishonchli avtomatlashtirilgan axborot tizimini ishlab chiqishdir.

Tizim arxitekturasi

Ishlab chiqilgan tizim uch qatlamli (three-tier) arxitektura asosida qurilgan. Birinchi qatlam — prezentatsiya qatlami, foydalanuvchi interfeyslarini HTML5, CSS3 va JavaScript (ES6) texnologiyalari yordamida amalga oshiradi. Ikkinchi qatlam — biznes mantiq qatlami, PHP 8.2 dasturlash tilida yozilgan bo‘lib, foydalanuvchi so‘rovlarini qayta ishlash, biznes qoidalarini bajarish va sessiyalarni boshqarish vazifalarini bajaradi. Uchinchi qatlam — ma’lumotlar qatlami, MySQL bilan to‘liq mos keluvchi taqsimlangan TiDB Cloud ma’lumotlar bazasi tizimi asosida qurilgan.

“KELAJAK TEXNOLOGIYALARI VA SUN’IY INTELLEKT”
nomli respublika ilmiy-amaliy masofaviy konferensiyasi
VOLUME-1, ISSUE-2, 2026

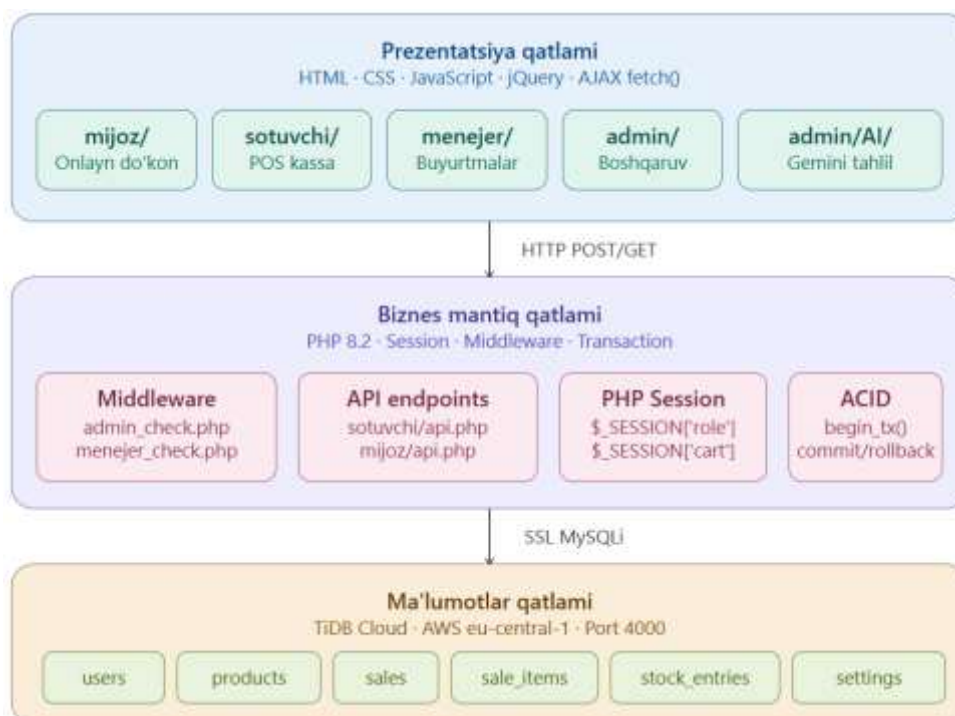

1-rasm. Tizimning uch qatlamli arxitektura sxemasi

Tizim besh xil foydalanuvchi roli uchun maxsus modullarga ega: superadmin (to‘liq nazorat), admin (boshqaruv va hisobotlar), menejer (omborni boshqarish va onlayn buyurtmalar), sotuvchi (POS kassa moduli) va mijoz (onlayn katalog). Har bir modul muayyan rolning vazifalariga maxsus moslashtirilgan, ortiqcha funksiyalardan tozalangan va intuitiv interfeysga ega.

Ma’lumotlar bazasini loyihalash. Ma’lumotlar bazasi yetti asosiy jadvaldan iborat: users (foydalanuvchilar), categories (kategoriyalar), products (mahsulotlar), sales (savdo cheklari), sale_items (chek tarkibidagi mahsulotlar), stock_entries (omborga kirimlar) va settings (sozlamalar). Jadvallar orasidagi munosabatlar birlamchi va xorijiy kalitlar orqali o‘rnatilgan. Ma’lumotlar bazasi normallashtirish jarayoni orqali uchinchi normal forma (3NF) holatiga keltirilgan, bu ma’lumotlar takrorlanishini minimal darajaga tushiradi va yangilanishlar samaradorligini oshiradi. Tranzaksiya jarayonlarida ACID tamoyillari to‘liq qo‘llaniladi. Masalan, sotuv operatsiyasi uch bosqichli atomar



“KELAJAK TEKNOLOGIYALARI VA SUN’IY INTELLEKT”
nomli respublika ilmiy-amaliy masofaviy konferensiyasi
VOLUME-1, ISSUE-2, 2026

tranzaksiya doirasida bajariladi: (1) sales jadvaliga yangi chek yoziladi; (2) sale_items jadvaliga har bir mahsulot satri qo‘shiladi; (3) products jadvalidagi qoldiq miqdori kamaytiriladi. Agar biror bosqichda xatolik yuz bersa, mysqli_rollback() funksiyasi chaqiriladi va barcha o‘zgarishlar bekor qilinadi. Bu yondashuv ma’lumotlar yaxlitligini to‘liq ta’minlaydi.

Xulosa. Mazkur tadqiqotda oziq-ovqat do‘konlari uchun mo‘ljallangan, uch qatlamli arxitekturaga ega avtomatlashtirilgan axborot tizimi ishlab chiqildi. Tizim PHP 8.2, MySQL bilan mos keluvchi TiDB Cloud, Docker konteynerlashtirish va RBAC xavfsizlik modeli asosida qurilgan. Ishlanma O‘zbekiston bozori sharoitlariga moslashtirilgan, besh xil foydalanuvchi roliga ega va ma’lumotlar yaxlitligini ACID tranzaksiyalar yordamida ta’minlaydi. Tizim Andijon viloyatidagi “Mahalla savdo” oziq-ovqat do‘konida ikki haftalik pilot rejimida sinovdan o‘tkazilib, 1 247 ta tranzaksiya muvaffaqiyatli amalga oshirildi (muvaffaqiyat darajasi — 99,76%).

Foydalanilgan adabiyotlar

1. Zulfikharov I.M., Atajonova S.B. The role of modern didactics in the effective organization of mathematics education. Kazakhstan University of Friendship of Peoples named after Academician A. Kuvatbekov. Shymkent, 12.04.2024.
2. Sommerville I. Software Engineering. 10th ed. — Boston: Pearson, 2016. — 816 p.
3. Sandhu R.S., Coyne E.J., Feinstein H.L., Youman C.E. Role-Based Access Control Models // IEEE Computer. — 1996. — Vol. 29, No. 2. — P. 38—47.
4. Zulfixarov I.M., Atajonova S.B. Methodology of Explaining to Students the Organization of Bayes Networks with Mathematical Considerations in Practical Lessons in Mathematics. Innova Science Journal of Theory, Mathematics and Physics. Vol. 3, No. 4, 2024. pp. 40–45.
5. Provos N., Mazières D. A Future-Adaptable Password Scheme // Proceedings of USENIX Annual Technical Conference. — Monterey: 1999. — P. 81—92.



TABLE OF CONTENTS | СОДЕРЖАНИЕ

1.	ROLE OF CONTINUOUS PHYSICAL ACTIVITY MONITORING IN THE PREDICTION OF GESTATIONAL DIABETES: OPPORTUNITIES OF WEARABLE DEVICES Kumar Nuratdinova	3–7
2.	Improvement of Technological Process Efficiency in Rolling Mills Umidjon Normengliyev	8–14
3.	Data Privacy Issues in the Use of Artificial Intelligence in International Arbitration and Mediation (On the Example of GDPR Requirements) Qahhorova Durдона	15–25
4.	Essential Pedagogical Competences for University English Language Teachers in Uzbekistan: Moving Toward More Effective and Modern Teaching Practices Mukhlisa Odilova	26–29
5.	ANALYTICAL INSTRUMENTS AND MODERN APPROACHES IN MANAGING FINANCIAL STABILITY Nao‘betova Ziyada	30–34
6.	Current Issues of Personal Data Protection in the Digital Age Aziza Donaeva	35–41
7.	ADAPTIVE LEARNING SYSTEMS IN TEACHING THE ENGLISH LANGUAGE Shavkat Ibragimov, Nozanin Ma‘murova	42–50
8.	THE IMPACT OF FUTURE TECHNOLOGIES AND ARTIFICIAL INTELLIGENCE ON THE GLOBAL ECONOMY Norqulova Sevinch	51–57
9.	METHODS OF MANAGING AND EVALUATING INVESTMENT PROCESSES Xolniyozov Asrorjon	58–62
10.	A Python Program for Automatic Detection of SQL Injection Attacks in Web Applications	63–70



“KELAJAK TEKNOLOGIYALARI VA SUN’IY INTELLEKT”
nomli respublika ilmiy-amaliy masofaviy konferensiyasi
VOLUME-1, ISSUE-2, 2026

	Mehmonaliyev Yahyobek, Umarov Abdulmuxtor	
11.	PERSPECTIVES AND CHALLENGES OF ARTIFICIAL INTELLIGENCE APPLICATION IN MODERN SOCIETY Khakimbekov Doniyorbek	71–74
12.	SECOND LANGUAGE ACQUISITION: KEY THEORIES AND INFLUENCING FACTORS Muxsinova Shaxzoda	75–81
13.	Media Literacy in the Age of Artificial Intelligence: Methods for Detecting Disinformation on Social Media Keldiyorova Ziyoda	82–88
14.	Ways to Improve the Professional Skills of a Science Teacher in the Age of Digital Technologies N. Utebaeva	89–94
15.	ANALYSIS OF NMR RESULTS FOR THE ALKALOID SKIMMIANINE Jalolov Iqboljon, Dolimova Umidaxon, Dolimov Xayotjon	95–103
16.	Household Consumption, Imports, and Investment Activity in Uzbekistan Murodil Isroiljonov	104–106
17.	Development of an Automated Information System for Grocery Stores Based on a Three-Tier Architecture Nasibonov Muhammadali	107–110